

**A TERM PAPER ON  
INNOVATIVE AND ADAPTIVE RESEARCH FOR  
IRRIGATION OF AGRICULTURAL FOODS. A CASE  
STUDY OF AFE BABALOLA UNIVERSITY**

**BY**

**OLAOYE ABASS AYODEJI**

**16/ENG03/061**

**COLLEGE OF ENGINEERING, DEPARTMENT OF  
CIVIL ENGINEERING**

**AFE BABALOLA UNIVERSITY, ADO EKITI.**

**IN PARTIAL FULFILMENT OF THE REQUIREMENT  
FOR THE AWARD OF BACHELOR OF  
ENGINEERING DEGREE (B.ENG) IN CIVIL  
ENGINEERING**

**February, 2020**

## **Abstract**

The improvement in irrigation system using wireless network is a solution to achieve water conservation as well as improvement in irrigation practices. This research attempts to automate the process of irrigation on the farmland by monitoring the soil water level of the soil relative to the plant being cultivated and the adaptively sprinkling water to simulate the effect of rainfall. Central to this design is an Arduino Uno microcontroller which monitors the farm condition and controls the distribution of water on the farm. This irrigation system allows farmers to reduce runoff from over watering saturated soils, avoid irrigating at the wrong time of day and in effect improve the crop yield by ensuring adequate water supply when needed.

## **Introduction**

Irrigation may be defined as the science of artificial application of water to the land or soil. It is used to assist in the growing of agricultural crops, maintenance of landscapes, and re-vegetation of disturbed soils in dry areas and during periods of inadequate rainfall. Automatic irrigation farming involves the use of a control system to control and monitor the irrigation process.

Agriculture is one of the fields where water is required in tremendous quantity. Wastage of water major problem in agriculture. Every time excess of water is given to the fields. There are many techniques to save or to control wastage of water from agriculture. There are different types of irrigation methods these are Ditch Irrigation, Terraced Irrigation, Drip Irrigation and Sprinkler System.

Soil moisture content is an essential factor in agriculture. In Nigeria today many acres of land (especially in the North) are not used because of low moisture content. This is due to the closeness of such areas to the desert. For such acres of land to be used for agricultural purposes, it is essential to irrigate the land. During the process of irrigation inadequate schedule of irrigation can result in wastage of water. A smart irrigation water sprinkler system prevents this by putting in place control mechanism to check the soil parameters and take action when the soil requires higher moisture content. A set point is programmed into the controller at such points the controller takes action to either put on the water pump or put it off. The water flows through the pipes and the sprinkler releases the water on the farmland. Most local farmers who practice manual irrigation, this takes more time and is not quite efficient. Agriculture is one of the fields where water is required in tremendous quantity. Wastage of water major problem in agriculture. Every time excess of water is given to the fields. There are many techniques to save or to control wastage of water from agriculture.

A GSM-SMS remote measurement and control system for greenhouse based on PC-based database system connected with base station. The base station was developed by using a microcontroller, GSM module, sensors and actuators. In practical operation, the central station receives and sends messages through GSM module. Criterion value of parameters to be measured in every base station is set by central station. These parameters include the air temperature and the air humidity. Modularization is adopted in the design of the system hardware, and the software exploitation is realized by embedded operating system, all of which make the system easy to be extended maintained and transplanted.

A system was proposed for the control of temperature and relative humidity inside a poly house. In the proposed method, the greenhouse controller senses the change in temperature and relative humidity with the help of input sensors and process the output to take appropriate control action. The proposed system is a low cost and user friendly system with high stability and reliability.

Wenbin designed a Remote Monitoring and control Systems based on GSM. GSM network is a medium for transmitting the remote signal and communication takes place between monitoring center and remote monitoring station. The central monitoring station performs real time control, alarm and data processing and also manages database. Receiving and sending of the data in the central monitoring station is achieved by using the GSM wireless communications module TC35. TC35 is introduced by SIEMENS which is a dedicated Modem. GSM module is interfaced using RS232 and accessed using AT commands.

GPRS technology was introduced in with better application prospect. The sensor node gathers the hydrographic information such as water-level, gate position and rainfall. The sink node receives the real -time data; the information centre stores and processes those data which are transmitted from the sink node through the GPRS network. The system replaces the wired transmission with the wireless transmission, which reduces the costs in instalment and maintenance, and improves the system's reliability and extension.

A Low cost soil moisture monitoring system is explained in. The paper describes a PC controlled irrigation monitoring and controlling system with wireless communication. The design of the overall system is based on: the system's ability to provide consistent soil moisture measurements at low cost; the system must interface with an irrigation system to allow for automatic watering of the soil; and the measurement units must be unobtrusive to everybody activity. PIC is used with Linx wireless system which used Amplitude Modulation to transmit data.

## **Methodology**

### **System model**

The complete block diagram of the developed system is shown in figure 1,

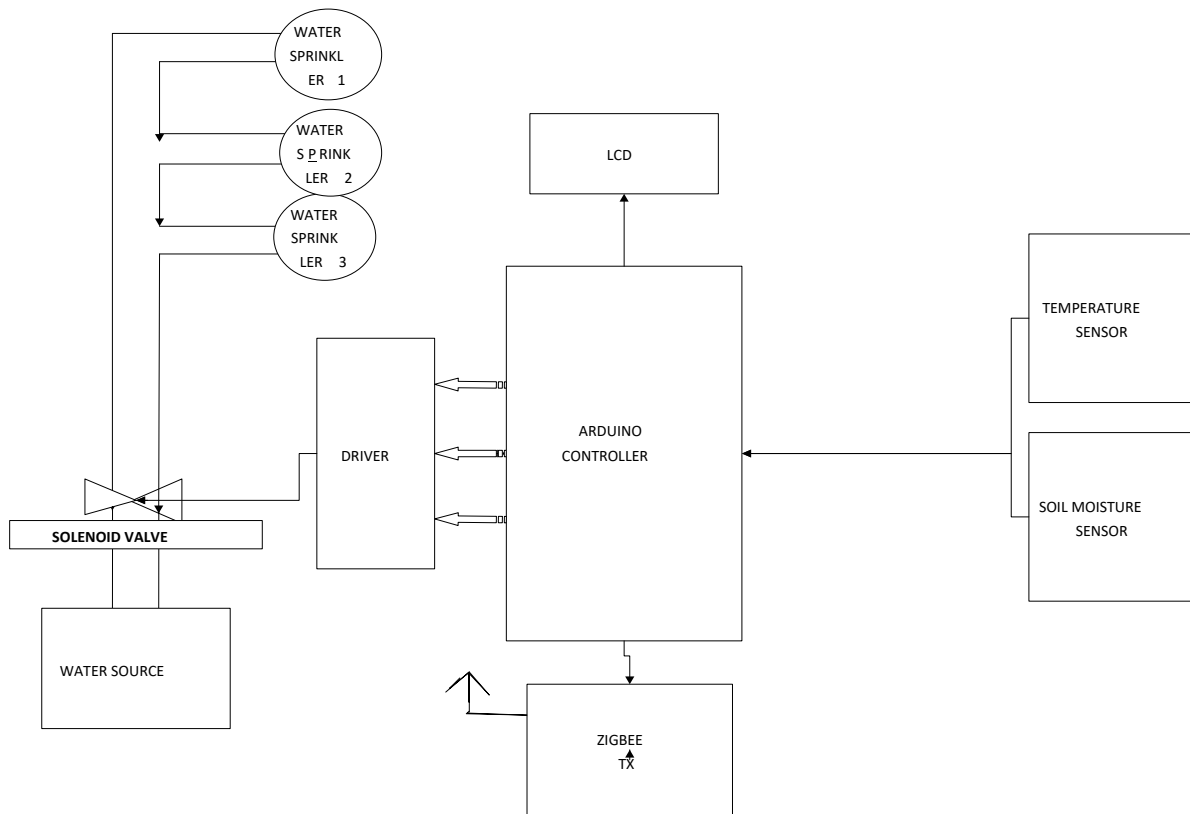

**Figure 1. Block Diagram of the System Transmitter**

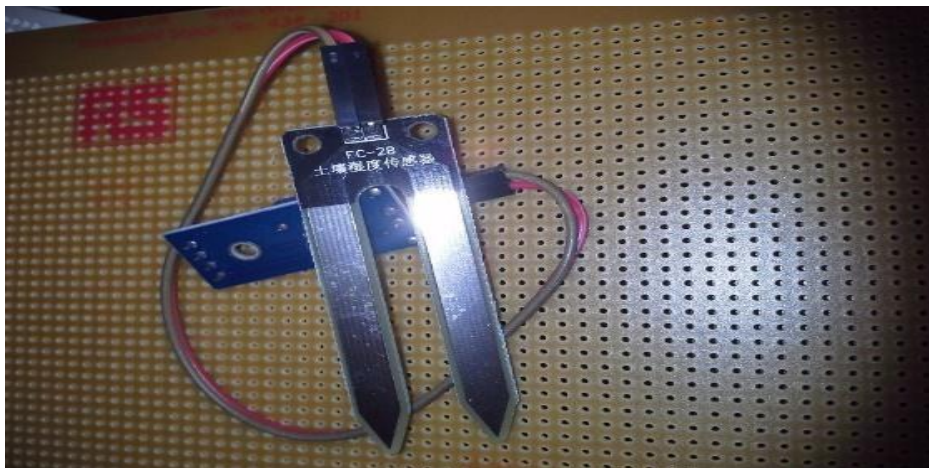

**Figure 2. Soil moisture employed for the work**

The sensor shown in Fig 2 was chosen because of its high sensitivity to the soil moisture content of the soil. This sensor was designed to estimate soil volumetric water content based on the dielectric constant (soil bulk permittivity) of the soil. The dielectric constant can be thought of as the soil's ability to transmit electricity. The dielectric constant of soil increases as the water content of the soil increases. This response is due to the fact that the dielectric constant of water is much larger than the other soil components, including air. Thus, measurement of the dielectric constant gives a predictable estimation of water content.

The temperature of the soil was measured using LM35 wrapped-in. The temperature and the soil moisture level measured are read using an Arduino Uno and the analogue values are converted appropriately and the result is displayed on the LCD while it is also sent to the Control room located few distances away from the farm land.

### ***A. Water Sprinkler System***

This consists of the layout of pipes on the farmland, water sprinklers, pipe connectors, solenoid valves and ball valve. The ball valve is used to connect 2 pipes together and manually control the flow of water.

#### ***1) Solenoid Valve***

The solenoid valve, shown in Fig 3, is an electromechanical device which allow an electrical device to control the flow of a gas or liquid. The electrical device causes a current to flow through a coil located on the solenoid valve. This current flow in turn results in a magnetic field which causes the displacement of a metal actuator. The actuator is mechanically linked to a mechanical valve inside the solenoid valve. The valve then changes state, either opening or closing to allow a liquid or gas to either flow through or be blocked by the solenoid valve.



**Figure 3. Solenoid valve**

#### ***2) Water Sprinkler***

As shown in figure 3.9, the water flows through the pipes to the sprinklers to the respective points on the farmland. A control signal from the microcontroller activates or deactivates the solenoid valve, hence, the water sprinkler based on the moisture content information acquired from the sensors. Most of the agricultural sprinklers are the hammer-drive, slow rotating impact type, single or twin nozzle. The sprinkler employed for this work, shown in Fig. 4 and Fig. 5 spins depending on the flow rate of the water.

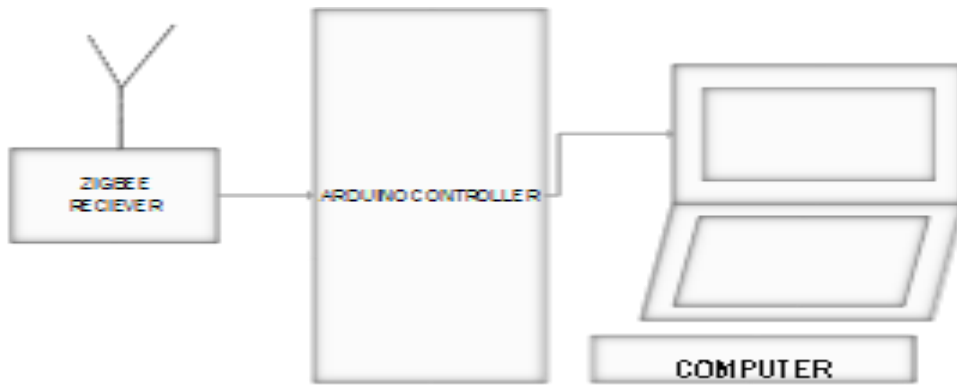

**Figure 4. Water Sprinkler**



**Figure 5. Water Sprinkler 2**

The sprinklers shoot jets of water into the air and spread it to the field in the form of raindrops in a circular pattern. This sprinklers are medium pressure capacity types with an angle of about 20°-30°. They are made of high plastics with internal and external threaded connections. They are installed vertically on small diameter riser pipes, 60 cm above ground, fitted on the laterals. The sprinkler spacing on the field was triangular at distances not exceeding 60 percent of their diameter coverage.



**Figure 6. Block Diagram of the System Receiver**

The important parameters to be measured for water sprinkler system are soil moisture and temperature. The soil moisture sensor measures the soil moisture content and the temperature sensor measures the temperature of the soil (Lincy et al 2013). The temperature sensor will detect /measure the soil temperature and the moisture sensor will sense the soil moisture level. These two signals are analogue signals which will be read and converted to digital values using the on-board ADC (analogue to digital converter) of the Arduino microcontroller operated in the 10 bit mode. The result after appropriate conversions will then be displayed on the LCD (liquid crystal display) and sent wirelessly to the farmer's control room using Bluetooth operating at 2.4 GHz.

The operation of the system at the hardware level is represented by the flow chart shown in figure 3.10. This shows the flow of operation in the automatic water sprinkler system. Arduino software is used, the code is written and compiled.

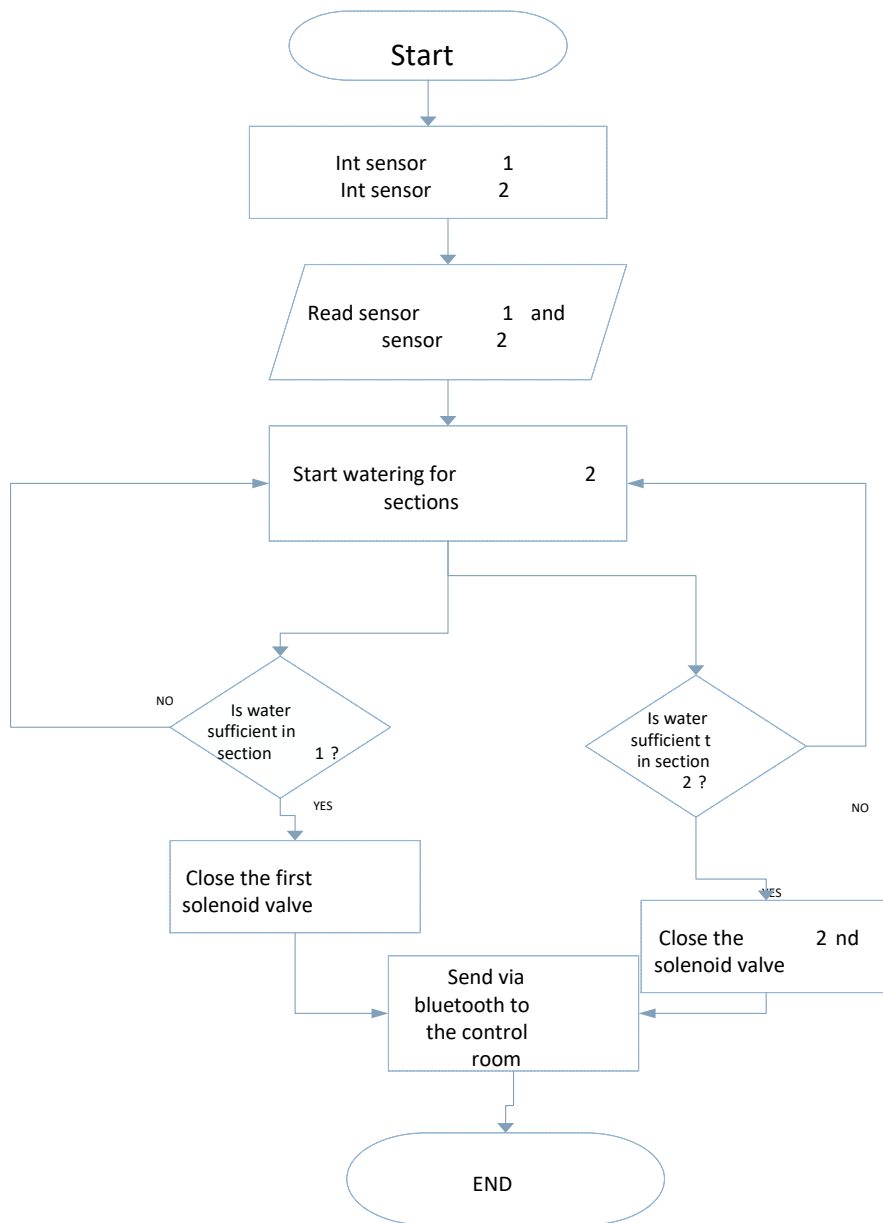
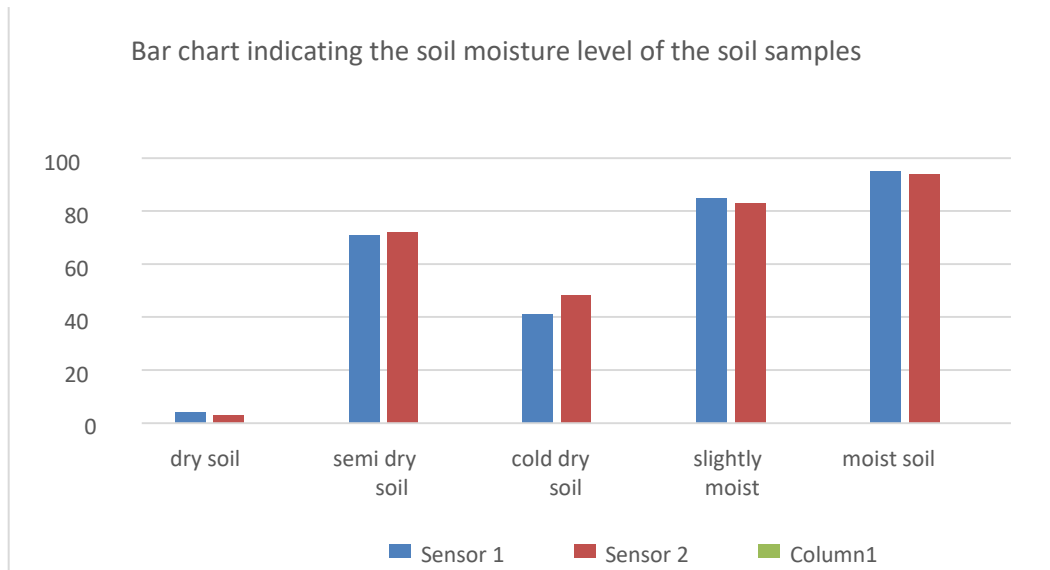

Figure 7. Flowchart of the system

## Result

This test was carried out in a portion of the grassy area in college of engineering Afe Babalola University. It was seen that the 2 sensors obtained slightly varied results when the probes were inserted into close range area of the farmland. When the soil is very moist the soil moisture sensor reads a reading above 60%. This is displayed on the LCD screen and it is transmitted via Bluetooth module to the farmer's computer. The LCD displays reading less than 60% when the soil moisture content is low.



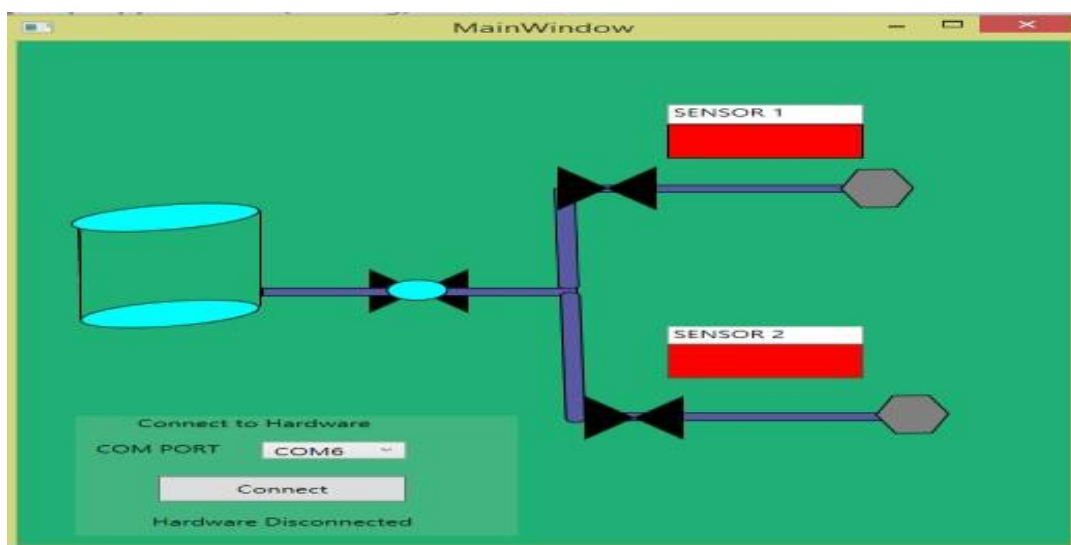

**Figure 8.** A bar chart indicating the soil moisture level of the soil sample

The sensors were used to test soil samples and readings were obtained that were used to plot a bar chart which is shown below. The height of the bar of the two sensors when the probes are inserted the farmland determines a high soil moisture content. Each sensor is connected to an individual relay and the readings determine the opening and closing of the solenoid valve.

A graphical user interface (GUI) was developed using Visual C# to monitor the activities of the sensors and the sprinklers on the farmland. Fig 8 shows the GUI.

Fig 8 shows the state of the GUI when the sprinklers are in the OFFLINE mode (that is, not running) while Fig 9 represents the state of the system when the sprinklers are in the ONLINE mode (that is, fully operational). The “red” colour indicates OFFLINE while the “green” colour indicates ONLINE. This makes it easy for the user (that is, farmer) to easily visualize which of the pumps are working and which one are not, especially when there is an array or network of pumps.



(a)

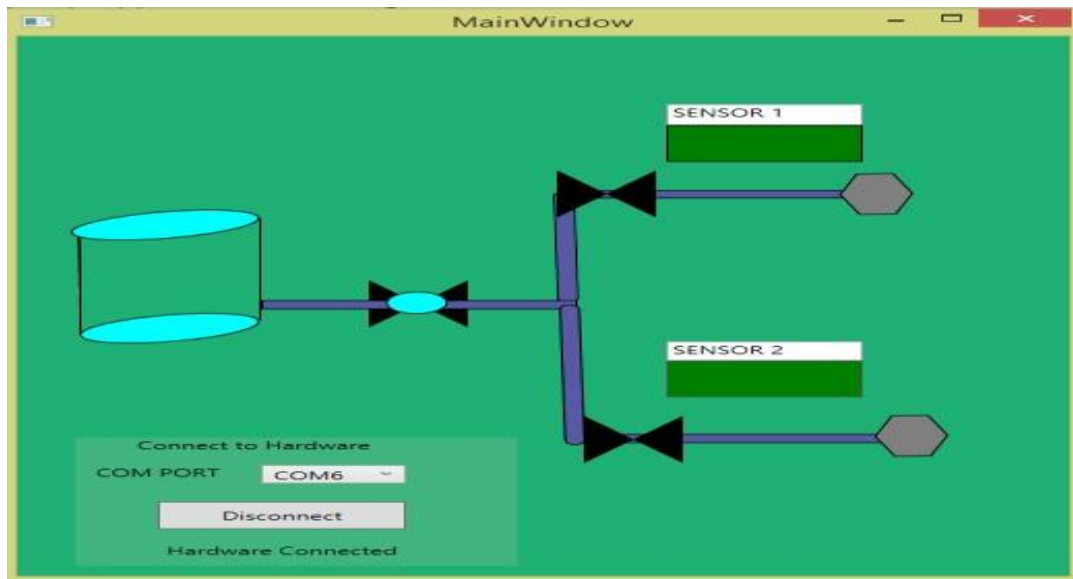

(b)

**Figure 9.** (a) GUI developed for Farm monitoring (OFFLINE) (b)GUI developed for Farm monitoring (ONLINE)

## Conclusion

The design and implementation of an automatic water sprinkler system for a farmland which monitors and controls a water sprinkler used for irrigation purposes on a farm has been annotated in this paper. This system is more efficient than the manual irrigation system and it reduces waste of water and is easy to implement on a farm. It saves time and attends to the plants water need at the right time and reduces human labour hours and errors and increases profit for the farmer.

## REFERENCES

- [1] Ahmed, V., "Innovative cost effective approach from cell phone based remote controlled embedded system for irrigation", International Conference on Communication Systems and Network Technologies, 2011, pp. 419-144.,
- [2] Banerjee G. K., Rahul Singhal, Bhubaneswar, Orissa India "Microcontroller Based Polyhouse Automation Controller", International Symposium on Electronic System Design, 2010, pp. 158162.
- [3] Healy, M. Newe, T. Lewis, "Wireless Sensor Node hardware: A review", IEEE 15th International Symposium on Consumer Electronics, 2011, pp. 621-624.
- [4] Shen Jin, Song Jingling, Han Qiuyan, Wang Shengde, Yang Yan, "A Remote Measurement and Control System for Greenhouse Based on GSM-SMS" School of Electric and Electronic Engineering IEEE 8th International Conference on Electronic Measurement and Instrument, 2007.
- [5] Wenbin Huang, Guanglong Wang, Jianglei Lu, Fengqi Gao, Jianhui Chen, "Research of wireless sensor networks for an intelligent measurement system based on ARM",

International conference on Mechatronics and Automation Conference, 2011, pp. 1074 - 1079.