

IWATT ENOBONG UDO

18/ENG04/080

ELECTRICAL/ELECTRONICS ENGINEERING

EEE326: ELECTRICAL MACHINES II

ASSIGNMENT

QUESTION ONE

(a) What is the limitation of single Phase Induction Motor?

Answer: A single phase induction motor, unlike a 3 phase induction motor, does not have a self-starting torque. Auxiliaries are required to start a single phase motor.

(b) Explain why a single phase induction motor does no self-start. Discuss this based on the double revolving theory.

Answer: The idea of double field revolving theory state that any alternating flux produced in the motor as a two equal components but of opposite direction. Hence the single voltage applied causes a forward and backward flux in the motor which are of equal magnitude thus there is rotation of the motor.

(c) Explain the constructional features and principle of operation of a Single Phase induction motor

Answer:

i.) The constructional features of the single phase induction motor are;

1. Stator
2. Stator winding
3. Rotor
4. Rotor winding
5. Terminal box
6. Fan
7. Bearing

8. Frame

ii.) The principle of operation. Firstly a pulsating magnetic field is produced, when the stator winding of the single-phase induction motor shown below is energized by a single phase supply. The word Pulsating means that the field builds up in one direction falls to zero and then builds up in the opposite direction. Under these conditions, the rotor of an induction motor does not rotate. Hence, a single phase induction motor is not self-starting. It requires some special starting means.

If the 1 phase stator winding is excited and the rotor of the motor is rotated by an auxiliary means and the starting device is then removed, the motor continues to rotate in the direction in which it is started.

(c) Using the double revolving field theory explain the torque –slip characteristics of a single phase induction. Hence explain why a Single-phase induction motor are not self-starting

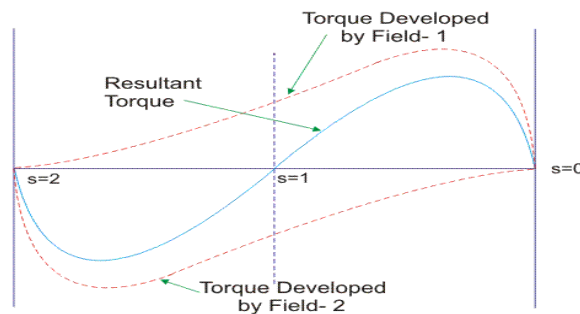

Answer:

Torque Slip Characteristics of Single Phase Induction Motor

From the diagram at unity the slip is 1, hence the backward torque and forward torque are the same and opposite hence they cancel out. But when any of the torque is increased in one direction either forward or backward the direction the motor start to move is in the increased direction for which the slip also decreases. Normally the torque decreases with a decrease in slip. However the exact point of maximum torque is maximum at a lower slip because of the resistive load.

(d) List five (5) types of Single Phase Induction Motor and explain explicitly any two with relevant circuit/connection diagrams

Answer:

1. Resistance start motor
2. Capacitor start motor
3. Capacitor start
4. Capacitor start, capacitor run motor
5. Permanent capacitor start motor

Resistance Start Motor. It has a single cage rotor, and its stator has two windings known as main winding and starting winding also known as the auxiliary winding. Both the windings are displaced 90 degrees in space. The main winding has very low resistance and a high inductive reactance whereas the starting winding has high resistance and low inductive reactance. The Connection Diagram of the motor is shown below.

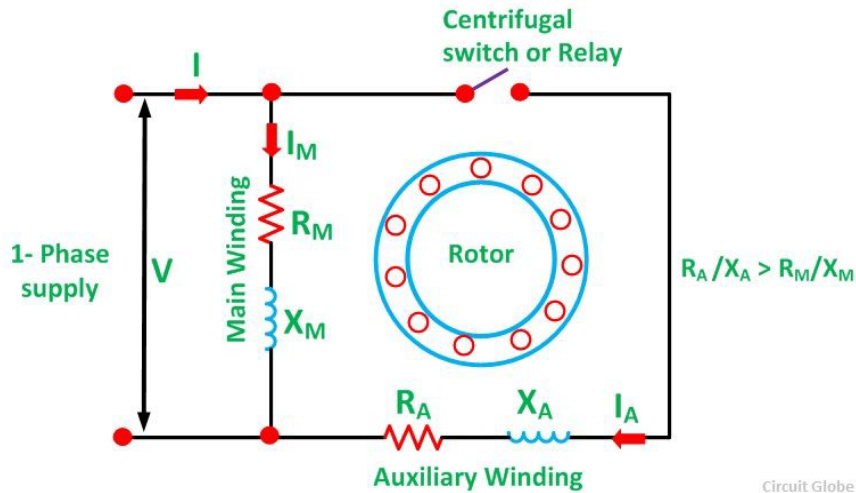

Capacitor Start Motors are a single phase Induction Motor that employs a capacitor in the auxiliary winding circuit to produce a greater phase difference between the current in the main and the auxiliary windings. The name capacitor starts itself shows that the motor uses a capacitor for the purpose of the starting. The figure below shows the connection diagram of a Capacitor Start Motor.

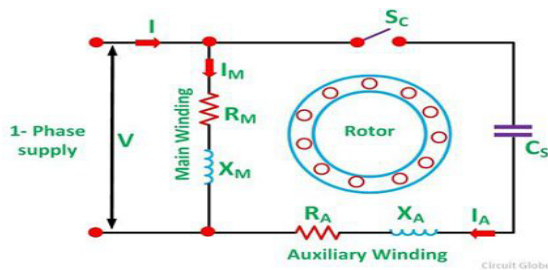

(e) Describe the operation of Single Phase Induction Motor using the Double-Field Revolving Theory.

Answer: The double revolving theory states that when a single phase supply excites a motor the alternating flux developed in the motors consist of a backward and forward field of

equal magnitude and opposite direction. The motor will only start if there is a slight push in any of the direction after which it follows the direction motion which is in the direction of the push.

QUESTION TWO

- (a) What is a Universal Motor? List five (5) areas of application of this type of motor.

Answer: A universal motor are motors that can operate on both dc and ac supply.

The applications of universal motor include the following. These motors are applicable where the control of speed & the motor speed high values are required. Used in handy drill machines, hairdryers, table fans, and grinders.

- (b) Describe the Construction of a Universal Motor.

Answer: The construction of a universal motor is as such with a series dc motor.

- (c) Distinguish Universal motor from the DC series motor with respect to the additional Constructional features. Describe these additional constructional features.

Answer: The universal motor is modified in several ways to allow for proper AC supply operation. There is a compensating winding typically added, along with laminated pole pieces, as opposed to the solid pole pieces found in DC motors. A universal motor's armature typically has far more coils and plates than a DC motor, and hence fewer windings per coil. This reduces the inductance. The laminated pole piece prevent eddy current loss.

QUESTION THREE

- (a) Describe the principle of operation of a three phase Induction Motor.

Answer: When the motor is supplied with a three phase supply. Magnetic field are generated in the rotor. This, magnetic field are 120 degrees out of phase. The magnetic field creates a current or induces a current in the rotor of the motor there by creating its own magnetic field that causes it to rotate when it interacts with the stator magnetic field.

- (b) State the advantages and disadvantages of Three Phase Induction Motor.

Advantages

1. They are low cost
2. Requires little maintenance
3. They are self-starting

Disadvantages

1. The speed decreases with increase in load.

(c) A 400V ,three phase, star connected induction motor has a stator impedance of $(0.06+j0.2)$ ohm and an equivalent rotor impedance of $(0.06+j0.22)$ ohm. Determine the maximum gross power output and the slip at which it occurs.

Answer

$$R_{o1} = R_1 + R'_2$$

$$R_{o1} = 0.06 + 0.06 = 0.12$$

$$X_{o2} = X_1 + X'_2$$

$$X_{o2} = 0.22 + 0.2 = 0.42$$

$$Z_{o1} = \sqrt{(R_{o1}^2) + (X_{o1}^2)}$$

$$Z_{o1} = 0.44$$

Slip corresponding to maximum gross power is= $R'_2 / (R'_2 + Z_{o1})$

$$S = 0.06 / (0.06 + 0.44)$$

$$S = 0.12 \text{ OR } 12\%$$

$$\text{Voltage phase} = V_{\text{line}} / \sqrt{3}$$

$$V_{\text{phase}} = 400 / \sqrt{3}$$

$$V_{\text{phase}} = 230$$

$$\text{Gross power output} = 3(V_1)^2 / 2(R_{o1} + Z_{o1})$$

$$P_{g\text{max}} = 3(230)^2 / 2(0.12 + 0.44)$$

$$P_{g\text{max}} = 141696.4 = 141.7 \text{ KW}$$

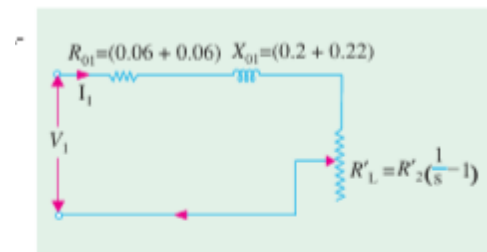

Hint: take k as unity, Solve using the approximate equivalent circuit referred to the Stator (Version 2)

(d) Draw and explain the Torque Vs Slip relationship of three-phase Induction Motor.

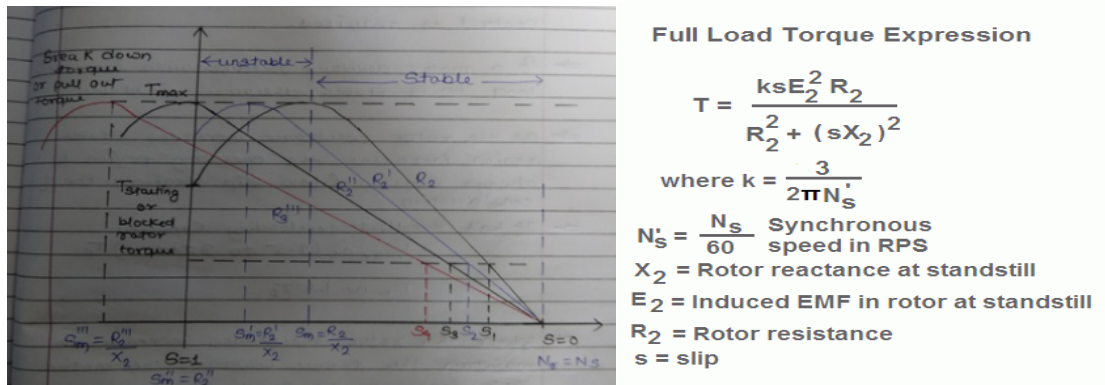

The relationship between the torque and slip relationship of the motor is shown in the figure above. Ideally with no load or resistance on the motor, when slip is 1 i.e the motor is standstill the torque generated is maximum, and as the slip approaches 0 the torque reduces to the minimum. Hence speed is maximum. So at maximum speed we experience minimum torque. However when a resistance is introduced the point of maximum torque occurs at a much higher speed depending the on the magnitude of the resistance.

(e) A **3-phase induction motor** runs at 20rps on no-load, and 15 rps at full load when supplied with power from a 60Hz, 3-phase source. Calculate the following;

i. The number of poles of the motor

Answer:

$$20\text{rps} = \text{rps} * 60 = \text{rpm}$$

$$20*60= 1200\text{rpm}$$

$$1200\text{rpm}= 120\text{f/p}$$

$$P= (120*60)/1200$$

Number of poles = 6 poles

ii. The percentage slip at full load

Answer:

$$15*60= 900\text{rpm}$$

$$\text{Slip} = (N_s - N) / N_s$$

$$\text{Slip} = (1200 - 900) / 1200$$

$$\text{Slip} = 0.25$$

$$\text{Slip} = 25\%$$

iii. The frequency of the rotor's voltage

Answer:

$$F' = SF$$

$$F' = 0.25 * 60$$

$$F' = 15\text{Hz}$$

iv. The rotor's slip speed

Answer

$$N_s - N = \text{slip speed}$$

$$1200 - 900 = 300$$

v. The rotor's frequency at a slip of 10 percent

Answer

$$F' = SF$$

$$F' = 0.1 \cdot 60$$

$$F' = 6\text{Hz}$$

QUESTION FOUR

(a) Highlight five methods of controlling the speed of Induction Motors

Answer: There are several ways to control the speed of an induction motor.

1 Reduce the voltage applied to the motor. (This reduces the amount of torque the motor can produce. Slip will increase and current may be well in excess of the full rated current.)

2 Control the current to the motor. (This also reduces the voltage, but if you can control the current directly, you can control motor heating.)

3 Use a wound-rotor motor and control the resistance applied to the rotor windings. (This works very well on loads that require long start times and large torques.)

4 Control the frequency and voltage applied to the motor. (This is the most popular option today.)

By injecting emf in rotor circuit

(b) List four methods of Starting the three phase Induction Motors

Direct-on-line starting

Reduced-voltage starting

Star-delta starting

Soft starter

(c) Explain any two methods in Q4(b) using appropriate circuit diagram

Reduced-voltage starting

The reduced-voltage starting method can be introduced into medium and large size induction motors to restraint the starting current. When the motor finishes the starting, it will resume to full pressure working. However, the result of reduced-voltage starting will lower down the starting torque. Therefore, the reduced-voltage starting is only suitable for starting the motor under no-load or lightly loaded condition.

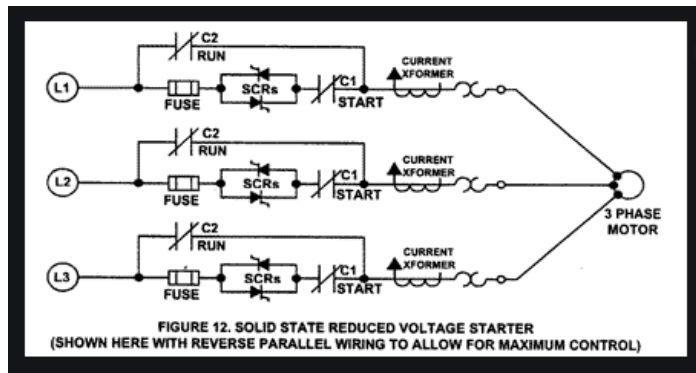

Soft starter

Soft starter is a new type control device whose main advantages include soft starting, light load and energy saving, and quickness. One of the most important features is that the electronic circuit is conducted in the silicon controlled rectifier of motor under the tandem connection of power supply. Using the soft starter to connect the power supply with the motor and different methods to control the conduction angle in silicon controlled rectifier can make the input voltage of motor increase gradually from zero and transfer all the voltage to motor from the beginning to the end, which is called soft starting. When starting in this way, the torque of motor will gradually increase with enhance speed. In fact, the soft starter is a voltage regulator that only changes the voltage without altering the frequency at starting.

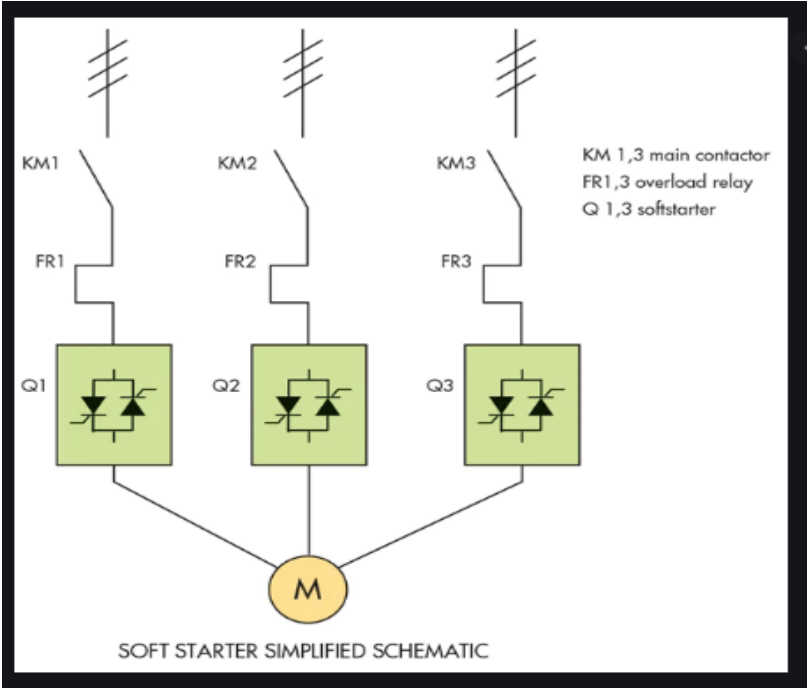

QUESTION SIX

(a) What is the importance of testing on three –phase Induction Motors

There could be many reasons to test an induction motor.

- To find out if it works.
- To test for reliability
- To see how much performance margin it has
- . To see if it works according to its specifications

The vibration test is used to detect the vibration level of a particular motor. The no load test is intended to find out the no load current, core loss, friction and windage losses and the blocked rotor test is carried out to determine the copper loss of motor.

(b) State two similarity and differences between the short-circuit test of transformers and the Blocked –Rotor test in Induction Motor.

Answer

Similarities

1. Both machine are short circuited.
2. A variac is supplied to both

Differences

1. The variac is applied to HV side of the transformer
2. Power is applied to the stator side/ secondary side of the motor

(c) State two similarity and differences between the Open circuit test in transformer and the No-load test in Induction Motor

Answer

Similarities

1. Both test do requires a no load correspondence
2. They are both used to determine the efficiency

Differences

1. Because of reduction on power factor the direction of measurement of current as to be changed in the induction motor whereas it is no needed for the open circuit transformer testing.

2. The rotor power factor reduces while that of the transformer remains at unity or some other unknown values

(d) List four types of testing carried out on three-phase Induction Motors and explain any one (1)

Answer: Generally the motor test can be classified into type and routine test. Type test includes

1. Winding resistance measurement,
2. load test and
3. Breakdown test.

Routine test includes

1. no load,
2. Blocked rotor
3. And insulation resistance.

Insulation resistance (IR) is the resistance measured between the windings of a motor and its ground / earth connection. It is measured in a very particular way. An IR test is measured with the application of a high voltage between the motor windings and the motor earth connection

(e) A 400-volts, three phase STAR connected Induction Motor gave the following results on no-load and short-circuit test

No Load Test	400V	3.0A	645 Watts
Blocked Rotor Test	200V	12.0A	1660 Watts

Given that the windage losses amount to 183 Watts, and the stator resistance as 5Ω ; determine the following;

- i. The Energy component of the No-load current
- ii. The magnetizing component of the No-load current
- iii. The power factor on No-load
- iv. No-load resistance, R_0
- v. No-load reactance, X_0
- vi. Equivalent resistance per phase as referred to the primary
- vii. Equivalent reactance per phase as referred to the primary
- viii. Power factor on Short Circuit

ix. Short Circuit current with normal voltage applied of 400V across the stator

Applied Voltage per phase, $V = 400V$, No load line current = 3A

No load phase current = $3/\sqrt{3} = \sqrt{3}A$, Input on no load = 645W

Stator copper loss = 45W, windage and friction loss = 183W

Total stator core loss = $645 - 45 - 183 = 417W$

$$\text{No load p.f, } \cos\phi = \frac{P_1}{3VI_0} = \frac{417}{3 \times 400 \times \sqrt{3}} = 0.2$$

No load line current on energy = $I_0 \times \cos\phi = 3 \times 0.2 = 0.6A$

Magnetizing component of no load line current,

$$I_{lm} = \sqrt{(I_0)^2 - (I_e)^2} = \sqrt{3^2 - 0.6^2} = 2.94A$$

Energy component or no load phase current,

$$I_e = I_0 \cos\phi = 1.732 \times 0.2 = 0.3464A$$

No load resistance,

$$R_0 = \frac{V}{I_e} = \frac{400}{0.3464} = 1.155\Omega$$

No load phase current,

$$I_m = \frac{2.94}{\sqrt{3}} = 1.7A$$

No load reactance,

$$X_0 = \frac{V}{I_m} = \frac{400}{1.7} = 236\Omega$$

Short Circuit Voltage = 200V, short circuit stator line current = 12.0A

Short Circuit stator phase current = 6.928A, Input on short circuit = 1660W

Equivalent resistance per phase as referred to the primary,

$$R_0 = \frac{P_s}{3I_s^2} = \frac{1660}{3 \times (6.928)^2} = 11.53\Omega$$

Equivalent reactance per phase as referred to the primary,

$$Z_0 = \frac{V_s}{I_s} = \frac{200}{6.928} = 28.87\Omega/\text{phase}$$

$$X_0 = \sqrt{Z_0^2 - R_0^2} = \sqrt{(28.87)^2 - (11.53)^2} = 26.5\Omega$$

Power factor on short circuit,

$$\cos\phi_s = \frac{P_s}{3VI_s} = \frac{1660}{3 \times 200 \times 6.928} = 0.4$$

Short Circuit current with normal voltage applied of 400 V across the stator,

$$I_{sc} = \frac{I_s \times V}{V_s} = \frac{12 \times 400}{200} = 24A$$

QUESTION SEVEN

(a) Explain the operation of synchronous generator

First, the basic principle of generating electricity: you need a conductor to carry the current, a magnetic field to move electrons through the conductor and relative motion (back and forth, side to side, what have you) between the two.

In the case of an AC generator, the magnetic field is created in the rotor, which is an even number of iron cores (bars) wrapped with a length of wire to create alternating north and south poles. This done by wrapping the wire one way around one pole and wrapping the wire the other way around the next pole. Direct current is applied to the wire to create a stable and constant magnetic field on the poles of the rotor.

The actual alternating current is generated in the coils of wire that are looped around the outside part of the generator, the stator. The magnitude of that voltage is partially determined by the number of times the wire is looped around the stator, giving the magnetic field more conductors to pass over and thereby move more electrons through the wire. A three phase AC generator has three sets of coils, each set consisting of one wire, wrapped the same number of times around then length of the generator so that they each have the same output voltage.

Output voltage is determined by the speed of the rotor (directly correlated to the speed of whatever is attached to the generator, whether a diesel engine, gas, steam, hydroelectric or wind turbine), the number of poles built into the rotor and the strength of the magnetic field they create (directly correlated to the DC applied to the rotor coils) and finally the number of coils in the stator.

Since the number of poles and number of coils are fixed when the generator is built and installed,

the only way to adjust the output voltage to the desired level is to adjust speed and magnetic field strength. However, since alternating current runs at a requisite frequency (60 cycles per second in America and a few other countries, 50 cycles per second in most everywhere else), the speed of the rotor has to be constant to maintain that frequency. That only leaves the magnetic field strength available to alter the output voltage, which is accomplished by altering the amount or current that is sent into the coils of the rotor.

Once a load is attached, and output power from the prime mover is applied to work out on the power grid, output voltage and frequency will drop because current running through the stator will create an opposing magnetic field in the stator, which will oppose the magnetic field created by the rotor. Power to the prime mover AND current to the rotor coils will need to be increased to maintain frequency and voltage at the required parameters; the reverse applies when load decreases as customers turn their appliances off.

(b) A Y connected, two pole, 50 Hz, 11kV, 10MVA synchronous generator with $X_s=150\Omega$ is operating at full load and 0.8 power factor lagging. Calculate the following

- i. The induced emf and load angle, $E_f < \delta$
- ii. The maximum power, P_{max}
- iii. The maximum Torque

S/MVA rating=10MVA, $V_{line} = 11KV$, p.f.=0.8, $X_s = 15\Omega$, $f=50Hz$, number of poles=2

Induced emf is given as;

$$I_{a(line)} = \frac{V_{t(line)}}{\sqrt{3}}$$

So;

$$|E_{f(phase)}| = \sqrt{(V_{t(phase)} \cos\phi)^2 + (I_a X_a \sin\phi)^2} = 12,741KW$$

$$\cos(\phi + \delta) = \frac{V_{t(phase)} \cos\phi}{E_{f(phase)}} = \frac{(6351)(0.8)}{12,741} = 0.399$$

$$\phi + \delta = \cos^{-1}(0.399) = 66.5^\circ$$

Recall;

$$\cos\phi = 0.8$$

$$\phi = \cos^{-1}(0.8)$$

$$\varphi = 36.90$$

Hence,

$$\delta = 66.5 - 36.9 = 29.6^\circ$$

ii.) Maximum power,

$$P_{\max} = \frac{3|V_t||E_f|}{X_s} = \frac{3(12,741)(6351)}{15} = 16,138,618.22\text{W}$$

iii.) Maximum torque,

$$T_{\max} = \frac{P_{\max}}{2\pi f} = \frac{16,138,618.22}{2 \times 3.142 \times 50} = 51,507.4\text{Nm}$$

(c) Explain the concept of parallel connection of generators and give four (4) advantages of connecting generators in parallel.

Connecting generators in parallel increases the power capacity, control in load management, ease of maintenance, and redundancy. The process involves the physical connection of two or more electric generators, and the synchronization of their outputs.

The synchronization matches the waveform of the output voltage of one generator with the voltage waveform of the other generator (s).

Benefits of parallel operation include

Redundancy: failure of one unit does not affect the integrity of the power supply, generators may be taken out of service for preventative maintenance

Scaling: many units can combine to provide a power demand, rather than requiring fewer very large generators

Resource management: generators can be located and operated to best meet the generating conditions, instead of having to be located and operated to meet the requirements of a local load. An example of this may be a nuclear power plant, which may take many weeks to bring up to full operating conditions. Using a nuclear generating station at full power to meet a "base load" with smaller more rapid response generators is one way to supply fluctuating load requirements.

Efficiency: Generators operating at full load are more efficient than those operating at low loads. It is more efficient to meet a changing load by adding or removing smaller generators than having a single large generator operating inefficiently.