

NAME: UYAEBO EBUBECHUKWU

MATRIC NO: 15/ENG04/059

1. Working principle

3G.

3G simply stands for “third generation.” It surpasses previous generations it is generally intended for multimedia, cellphones i.e. The use of 3G technology is also able to transmit packet switch data efficiently at better and increased bandwidth. 3G mobile technologies proffers more advanced services to mobile users. It can help many multimedia services to function. The spectral efficiency of 3G technology is better than 2G technologies.

3G technologies make use of TDMA and CDMA. 3G (Third Generation Technology) technologies make use of value added services like mobile television, GPS (global positioning system) and video conferencing. The basic feature of 3G Technology (Third Generation Technology) is fast data transfer rates. However, this feature is not currently working properly because, ITU 200 is still making decision to fix the data rates. It is expected that 2mbit/sec for stationary

users, while 348kbps when moving or traveling.

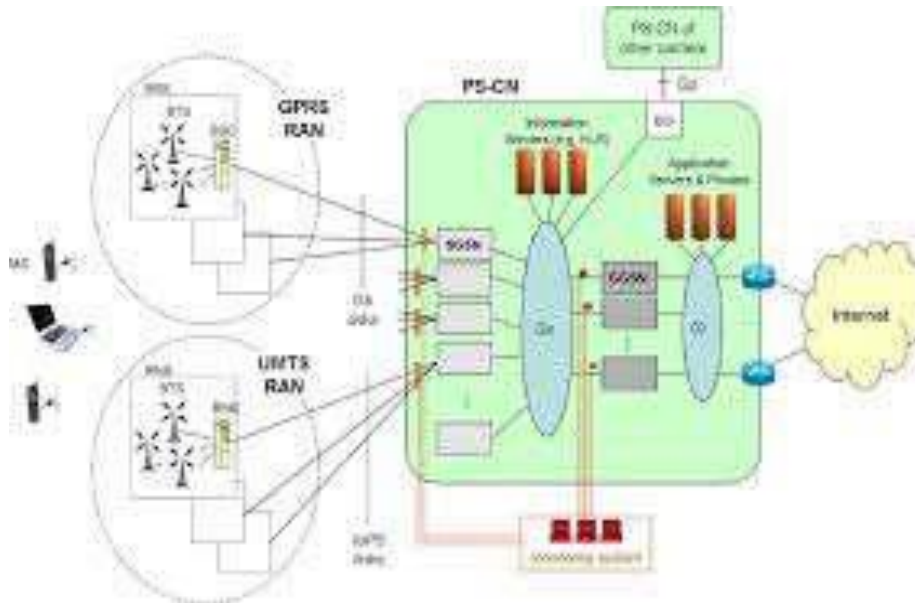

3G technology is much flexible, because it can support the 5 major radio technologies. These radio technologies operate under CDMA, TDMA and FDMA. CDMA holds for IMT-DS (direct spread), IMT-MC (multi carrier). TDMA accounts for IMT-TC (time code), IMT-SC (single carrier). FDMA has only one radio interface known as IMT-FC or frequency code. Third generation technology is affordable due to the agreement of industry. This agreement took pace in order to increase its adoption by the users. 3G (Third Generation Technology) system is compatible to work with the 2G technologies.

4G.

Working principle of 4G Network: “4G” essentially stands for fourth generation. 4G very works the same way as 3G but faster. It uses high speed download and upload packets. Users can normally access speeds up to 21mb on the ago depending on the location. It is essentially a highly advanced radio system. Where masts broadcast signals for 4g to work. 4g is a protocol that sends and receives data

in packets, and it is entirely IP based. It works through your devices by communicating with a base station which are the masts. These masts relay data from your device to the internet and vice versa. Fully IP based Mobile System. It supports interactive multimedia, voice, streaming video, internet and other broadband service, It has better spectrum efficiency and also supports Ad-hoc and multi hop network.

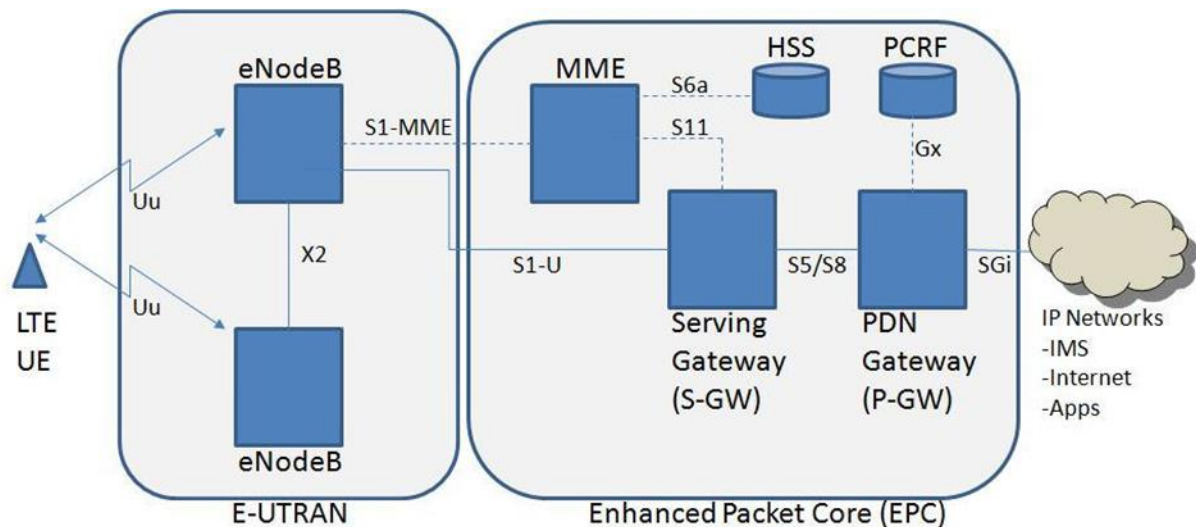

5G

Working principle of 5g network: This is the 5th generation of mobile wireless systems. It integrates perfectly with the internet of things like other cellular networks, 5g uses a system of cell sites that divide their territory into sectors and send encoded data through radio waves. Each cell site must be connected to a network backbone,

whether it is wired or wireless connection. It uses a type of encoding called OFDM, which is similar to the encoding 4gLTE uses.

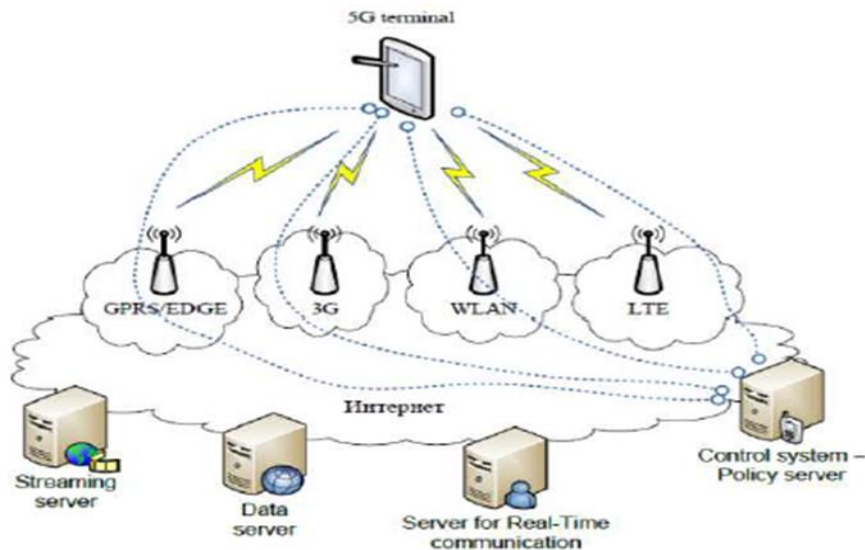

1B. Advantages of 3G

1. Faster data rates
2. Support multimedia applications such as video and photography
3. Value added service like mobile television, GPS, video call and video conferences.
4. High speed mobile internet access
5. Increased capacity

Disadvantages of 3G

1. Requires 3G compatible handsets
2. The cost of upgrading to 3G device is expensive
3. Power consumption is high
4. 3G requires closer base station which is expensive

Advantages of 4G

1. Quickly download files over a wireless network
2. Extremely high voice quality
3. Easily access internet, IM, social networks, streaming media, video calling, etc.
4. Higher bandwidth
5. Seamless network of multiple protocol and air interfaces.

Disadvantages of 4G

1. New frequencies mean new components in new cell towers
2. Higher data prices for consumers
3. Consumers is forced to buy a new device to support the 4G
4. It is impossible to make your current equipment compatible with the 4G networks.
5. Carriers and providers must plan carefully to make sure that expenses are kept realistic

Advantages of 5G

1. High resolution and bi-directional large bandwidth shaping
2. Technology to gather all networks on one platform
3. More effective and efficient
4. Technology to facilitate subscriber supervision tools for the quick action.

Disadvantages of 5G

1. 5G is more costly compared to other Mobile network technology because many technical/ official engineers are required to install and maintain it.
2. The risk of overcrowding the frequency range of the 5G wireless spectrum is greater as more devices are connected to one channel
3. 5G network technology will take more time for security and privacy issues.
4. High cost of 5G infrastructure.

QUESTION 2

FEATURE	2G	3G	4G	5G
Core network	PSTN	Packet network	Internet	Internet
Web standard	www	www (IPv4)	www (IPv4)	Wwww (IPv6)
Frequency	1.8 GHz	1.6 – 2 GHz	2 – 8 GHz	3 – 30 GHz
Bandwidth	14.4-64 kbps	2 Mbps	200Mbps-1Gbps	1Gbps and above
Handoff	Horizontal	Horizontal	Horizontal& vertical	Horizontal& vertical

QUESTION 3

3a. There is no correlation between 5g and Coronavirus.

3b. 5G networks essentially are made up of radio frequency when you take away both its speed and its reliability which is an electromagnetic wave. Essentially electromagnetic (EM) waves are divided into two types, let's call them type A and type B electromagnetic waves.

Type A: These EM waves have lower frequencies, are packed with lower energies and consequentially, are relatively less harmful. Examples are Radio frequencies, Infrared waves, and visible light and ultraviolet rays.

Type B: These types of waves have extremely high frequencies and power and could cause damage to humans and biological matter. Examples are X-rays and Gamma rays.

As a general rule, how harmful electromagnetic waves are depends on the frequency of the wave, which also translates in their ability to penetrate objects. The lower the frequency the less harmful it is. And radio waves appear to be less harmful. In relation to the viruses and Covid-19, They are extremely tiny, and they don't just affect humans they affect and living organism ranging from bacteria to horses; seaweed to people.

It is known that bats are the natural reservoirs of the coronaviruses which Covid-19 is a form of. Virus reservoirs are one of several animals that cannot or have little sensitivity to the virus due to their immune system and bats have insanely strong immune systems. What makes the virus so deadly is the facts that the virus replicates faster in bats due to their fierce immune systems, such that they jump to mammals.

As far as we know, COVID-19 got transmitted from a Bat to a Pangolin and then to a human. Considering how obsessed we (humans, including us Nigerians) are with Pangolins, the transmission to humans is not difficult to imagine. Viruses jumping from one organism to another was expertly depicted in the 2011 movie; Contagion where we see a virus make its way from Bat to Pig and then to humans.

In summary, COVID-19 and 5G technology are two things that exist at the two ends of completely separate universes. One is a contagious virus that is in no shape or form related to electromagnetic waves and the other is wireless network technology that the WHO has classified as “Possibly carcinogenic” to humans right in the same bucket as caffeine and aloe Vera.

Other facts that make this theory nothing more than a conspiracy is the fact that the virus has hit countries like Zambia, Chad, Niger, Mali, etc. where 5G isn't even in use yet