

NAME: OLAOYE ESTHER OLUWASEUN

MATRIC NUMBER: 16/MHS01/189

DEPT: ANATOMY,400L

ANA 402

COURSE TITLE: ELECTRON MICROSCOPIC TECHNIQUE AND ULTRASTRUCTURE

1. Discuss the procedure involve in making of glass knife for cutting in ultrathin sections
2. Draw a knife maker and label it

Glass knives are used in an ultramicrotome to cut ultrathin slices of samples for electron and light microscope applications.

For resin and for cryosections, the knife edge must be extremely sharp, strong and stable. An important requirement for breaking glass knives of superior quality is the quality of the glass strips. Glass strips are produced from specially selected glass, the thickness and quality of which is precisely controlled. Only strict tolerances ensured by careful quality control allow breaking of two high quality knives from one square.

## The balanced break concept

The technique of producing a straight, controlled break in a strip of scientific-quality glass requires that the knife maker apply equal weight and pressure to each side of the score. In addition, the support elements that touch the glass from below must have minimum surface contact to avoid uncontrolled stress applied to the glass prior to the break.

In the balanced break method (Figure 1), a glass strip, is scored and broken into two equal halves. With an equal mass of glass on each side of the score, the break is balanced and the freshly fractured surfaces are plane. By continuing to divide each piece produced into two equal halves a certain amount of squared can be produced.

All squares have straight sides and precise right angled corners unlike squares produced from sequential breaking of a glass trip which have curved surfaces.

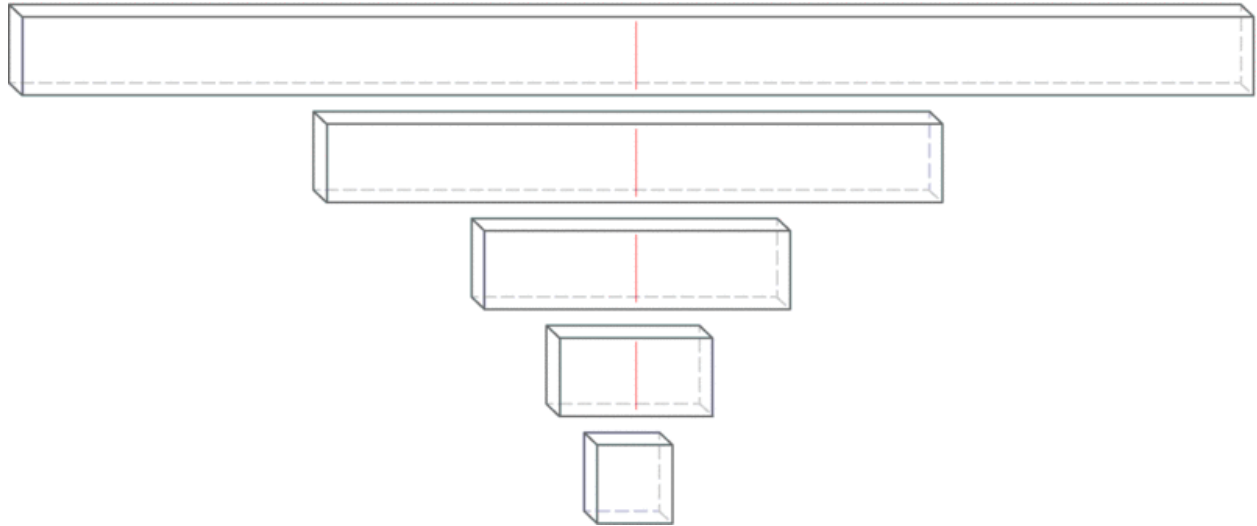

Fig 1:the balanced break method

## Scoring and breaking principles

Producing good glass knives routinely depends on a supply of reproducible squares, an accurately positioned score and controlled pressure precisely applied to make the break.

As a general rule, the knife edge is straighter and the counterpiece (knife shoulder) is small when the fracture occurs close to the corner (long score). Using a short score was in the past suggested for cryo knives as the free break is longer resulting in the sharpest, longest useable knife edge [1, 2].

Each score is preset and equidistant from the corners of the square. During the break the glass sits on two steel hemispheres and is held from above by two pins. The break follows the score line as far as it goes and then a free break occurs. The direction of this free break is determined by the mass of the glass on either side of the break and the breaking forces.

The free break curves to the edge of the square resulting in one knife and one flatedge counterpiece (knife shoulder) opposite the knife edge (Figure 2a). When the score runs centrally through a square a very small counterpice is obtained and the knife angle is very close to 45° (Figure 2b).

This is the optimal result for cryo knives. For resin sectioning, the user sets the knife shoulder adjustment a little larger (~0.5 mm), to produce a larger knife angle which is more stable for resin sectioning.

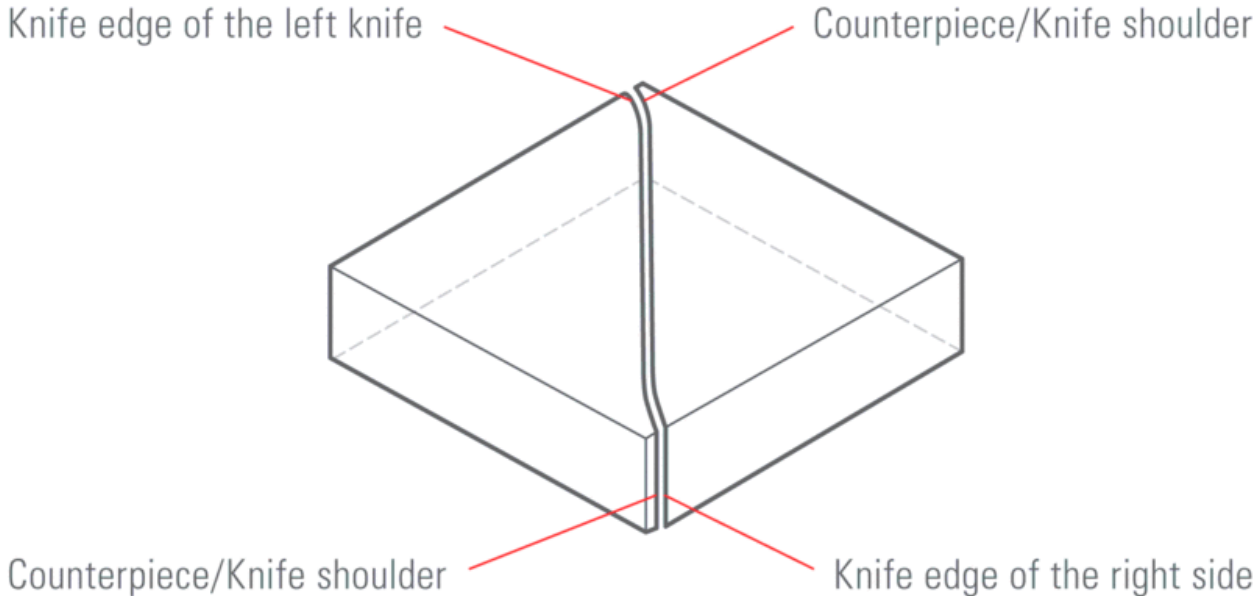

Fig2a.

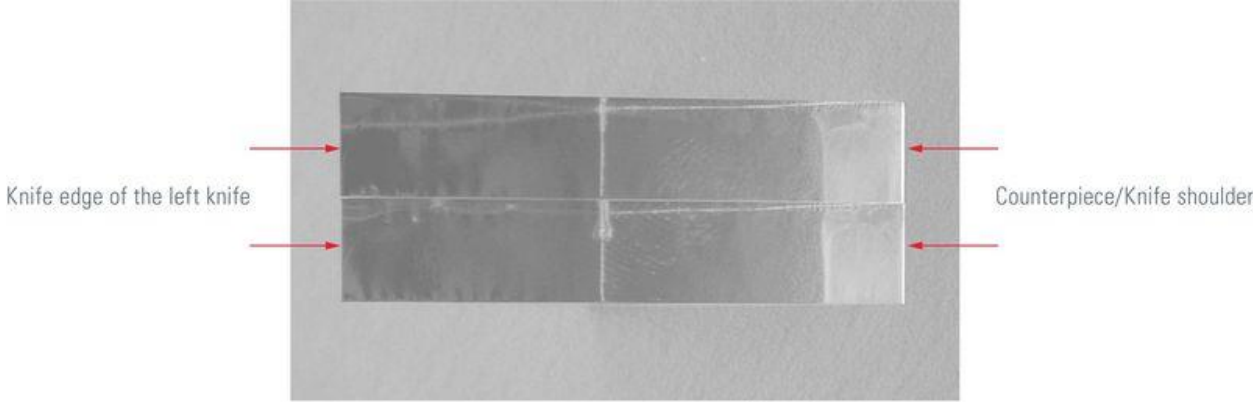

Fig2b.

## The real knife angle

When scoring the square all scores stop some distance from the corner. When pressure is applied under the score, the fracture is initiated and is seen first as a deepening of the score. The fracture extends towards the corners of the square following the line of the score. Where the score ends and the break is free, the fracture deviates from the line of the score to curve away from the corner, towards one of the edges of the square. This results in the real angle of the knife being somewhat greater than the angle of scoring.

The real angle of the knife increases as the score is moved further from the diagonal. This is when the knife shoulder becomes larger.

For example, when preparing knives from a square, the real angle of the knife is close to  $45^\circ$  when the knife shoulder is smaller ( $<0.5$  mm). Increasing the size of the knife shoulder ( $>0.5$  mm) results in an even larger knife angle which can be over  $55^\circ$  (Figure 3).

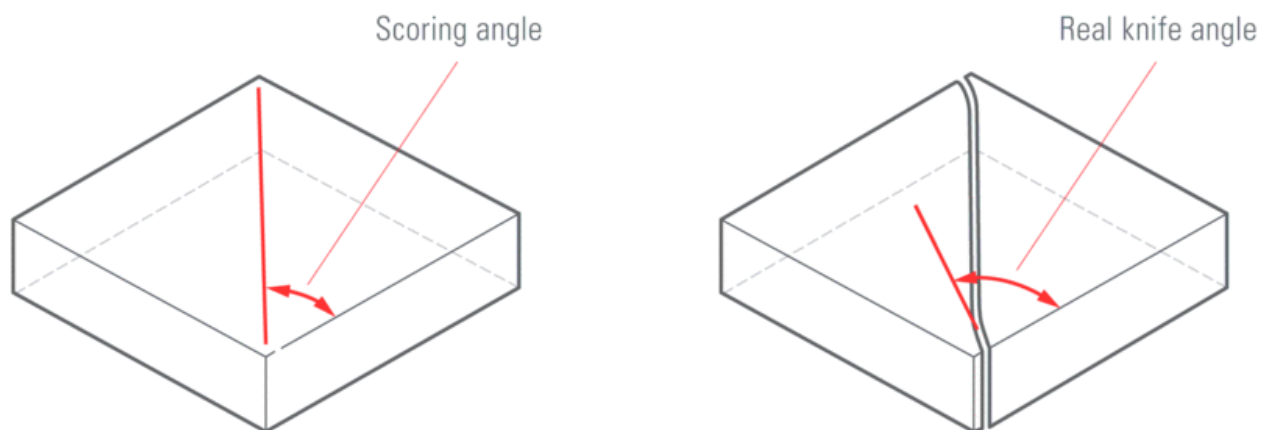

Fig3.

## Length of useful edge

When a glass knife edge is examined under darkfield illumination using a stereo microscope (or using back light on an Ultramicrotomes using ), it can be seen that the central part is most useful for ultrathin sectioning. The right side of the edge has visible

marks (saw teeth) which reduce the quality of the knife, and the left corner is also unsuitable for sectioning because of the stress line (Figure 4).

The useful knife edge starts where the stress line moves away from the knife edge until the part where the stress marks (saw teeth) can be seen.

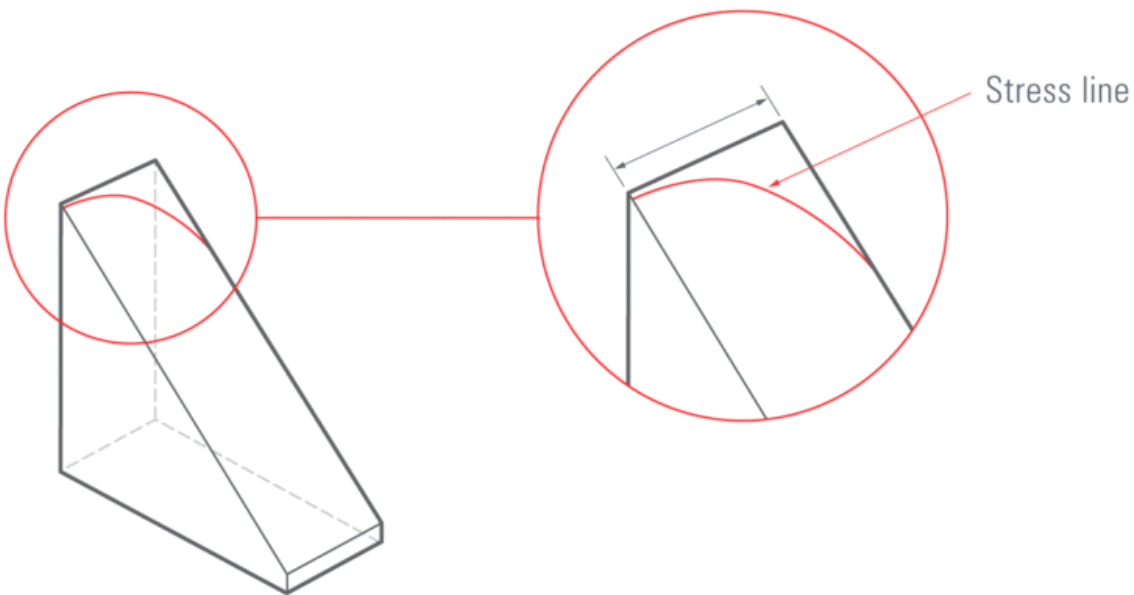

Fig4.

#### Important

- The useful knife edge is 30 % longer on knives produced from 8 mm thick glass compared to 6.4 mm thick glass!
- When less force has been used to break the knife, the stress line falls away rapidly from the knife edge and fewer saw teeth can be seen. Resulting in a longer usable knife edge.

## Evaluation of the knife edge

After making a pair of knives, evaluation of the quality can be carried out in an ultramicrotome.

Using the backlight illumination and setting the clearance angle to maximum a fine white line can be seen (Figure 5). The image of the line indicates the quality of the knife

edge, which must be straight, free of any dirt such as dust, grease and finger prints and free of glass splinters.

The top light of the ultramicrotome can also be used for checking knife quality (Figure 6).

An example of a knife which should not be used is shown in Figure 7. This has been picked up incorrectly leaving a finger print over the knife edge.

In Figure 8 (top) a pair of knives is shown, broken and placed side by side. The detail (Figure 8 bottom) shows the knife shoulder of both knives. The right hand knife edge was opposite the left hand knife shoulder during breaking and the left hand knife edge was opposite the right hand knife shoulder.

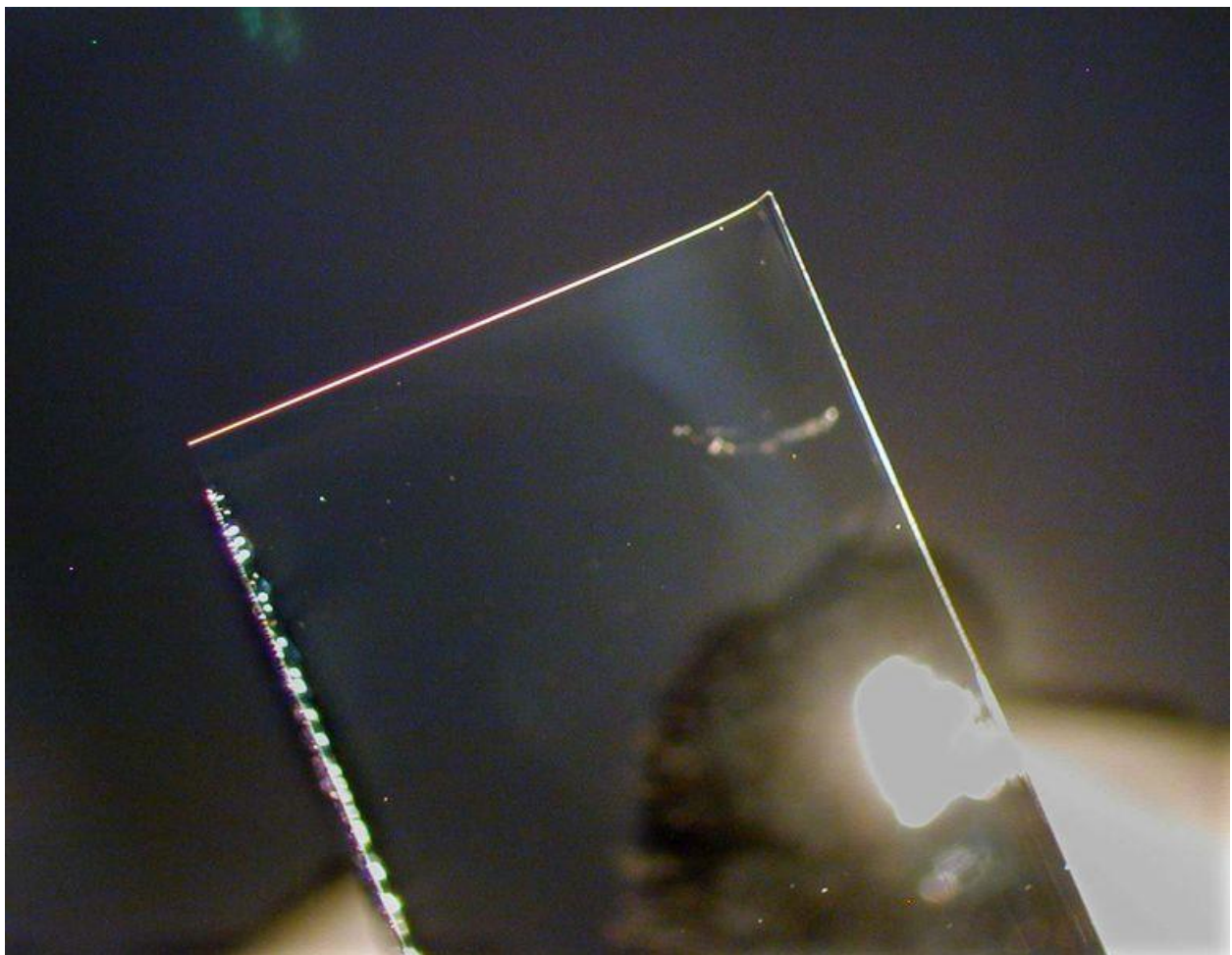

Fig5.

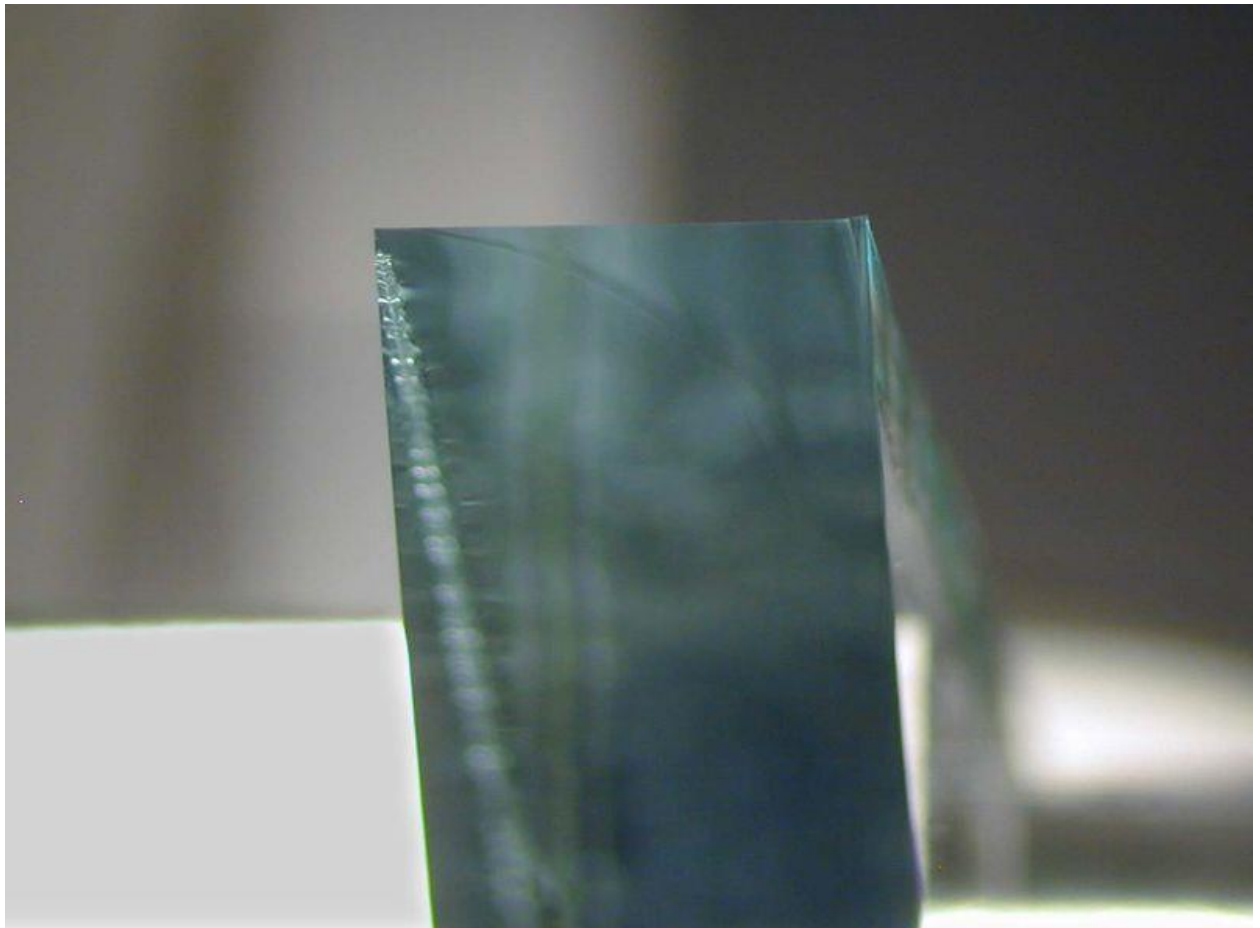

Fig6.



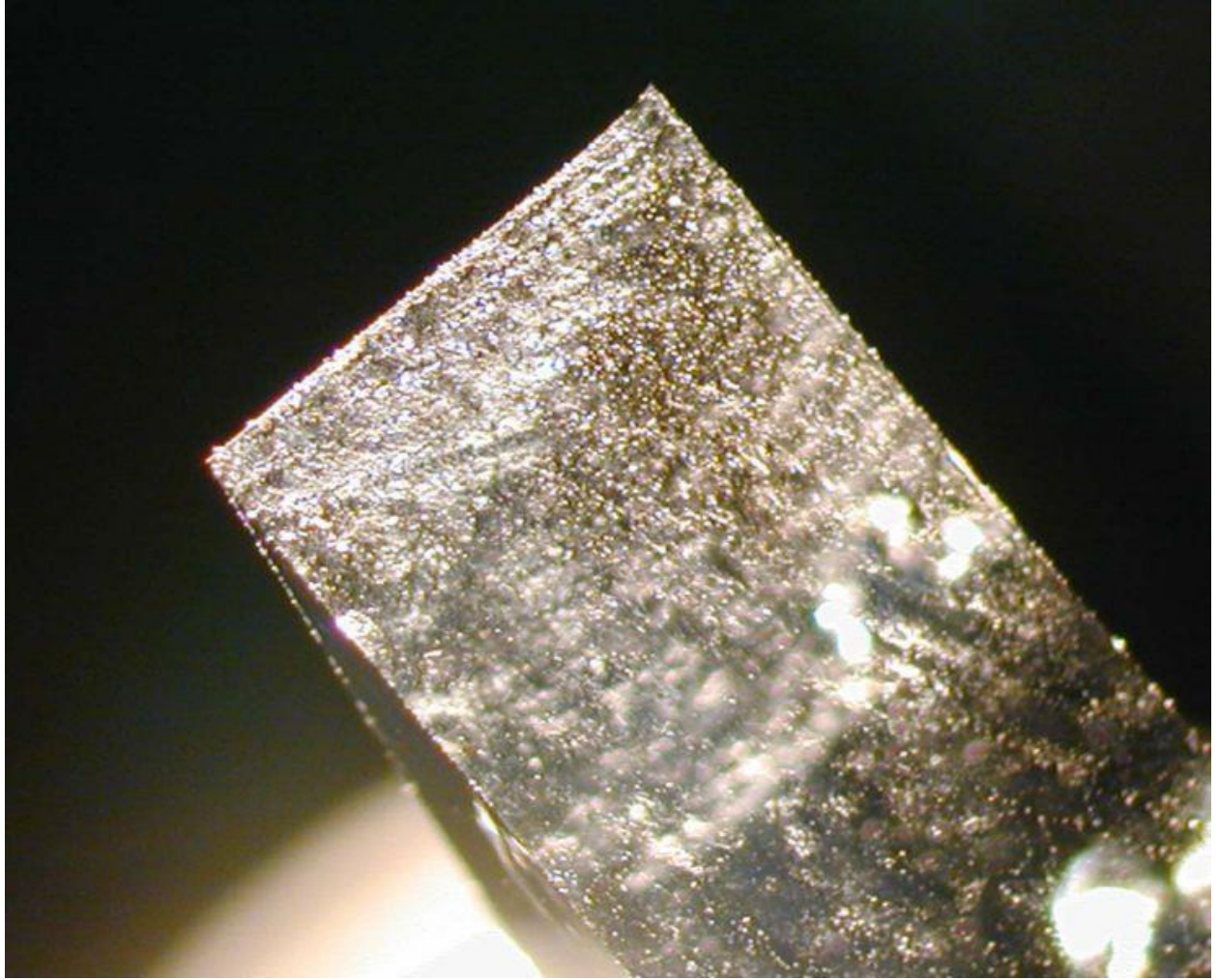

Fig7



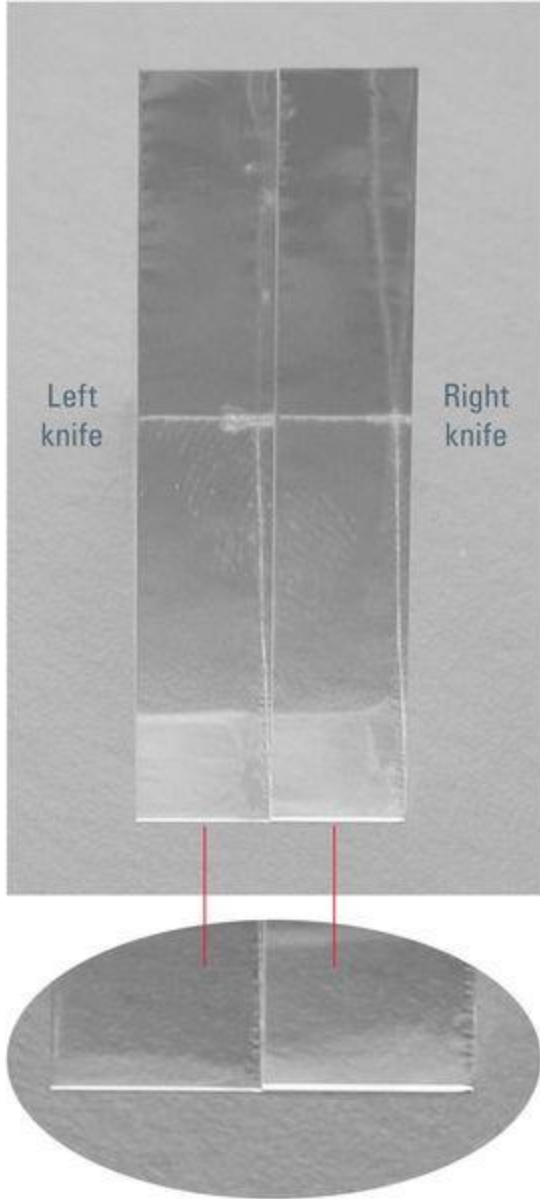
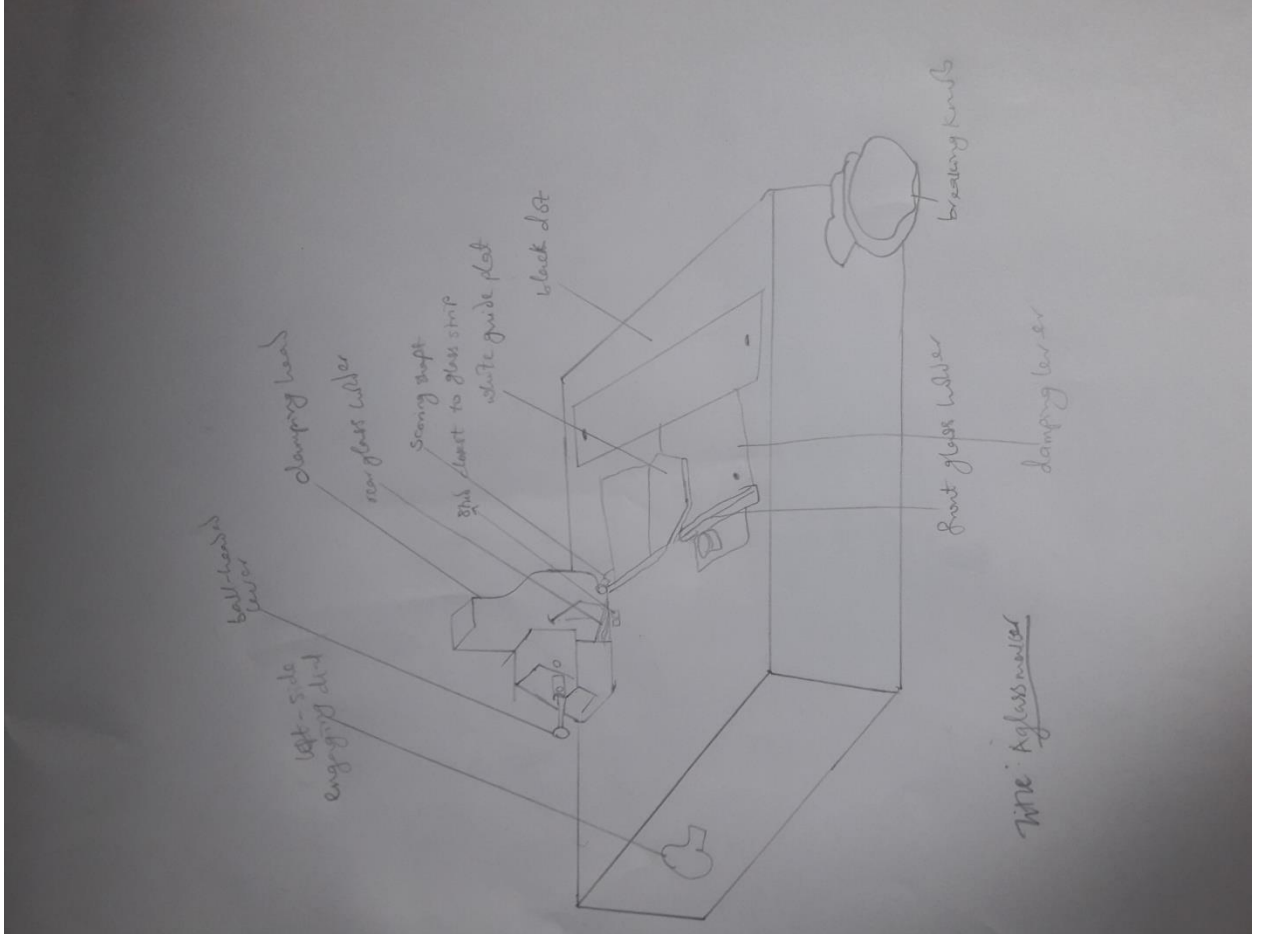

fig8.

2..



A glass maker.