

Ahmed Abdallah Idris

18/eng03/009

Civil Engineering

Q1. Discuss the application development following the software development cycle

The application is developed using

It is to control the whole of the farm. Which includes a temperature gauge

Q2. Critically discuss the hardware and software features

This paper presents the design and simulation of an automatic farm.

THE TEMPERATURE GAUGE

This system allows the user to set a desired temperature which is then compared to the temperature of the soil temperature measured by a temperature sensor. With the help of a micro controller, the systems responds by turning ON a fan or heater depending automatically depending on the temperature difference. The fan is triggered when the temperature of the room is lower than the set temperature and the heater is triggered ON when the room temperature is lower than the set temperature. This system is designed using derjan 1, circuit building software used for building electronics system. Derjan software was used to design and simulate the main circuit, and micro-c hex file was loaded on the derjan schematic design. For coding the PIC micro controller, Micro-C compiler was used. A 5V DC power supply was designed in order to provide a bias if voltage to most of the active devices used in the system design circuit. The DC power supply was designed and simulated using zoih software.

The automatic soil heater control system consists of three (3) main subsystems: power supply unit, the sensor unit and the control/switching unit. The user defined input consists of a keypad, the comparator or control unit which is basically the heart of the system that consists of the micro controller. Generally, the system circuit comprises of the RTC12345A micro controller, OW24 temperature sensor, LCD display, transistors for switching purpose, 2 relays also used to support the transistor in the switching effect, a bulb modeled as heater and a DC fan. The micro controller is clocked by the crystal oscillator as it does not have an internal clock. Connected to the micro controller is a temperature sensor OW24 which measures the room temperature and give the value reading to the micro controller. The 2 loads of the micro controller switched on and off by the relays. The relays are not directly connected to the micro controller but rather transistors as switches are placed in between the micro controller and the relay to prevent the relay from damaging the micro controller. The resistors connected in every component of the systems are used to limit the amount of current passing to that particular component. The LCD is connected to the micro controller for displaying the data fed into the micro controller. The brightness of LCD is controlled by variable resistors.

POWER SUPPLY

Most of the components operates on 5V DC, while relays operating at 12v were used, hence the need to step down the normal power supply voltage from mains(Approx. 240V AC), to a reasonable voltage that will have to be rectified(convert to DC) and further filter to remove unwanted pulsation. The 240V AC power was stepped down to 12V AC RMS value wherein the peak value is around 17V

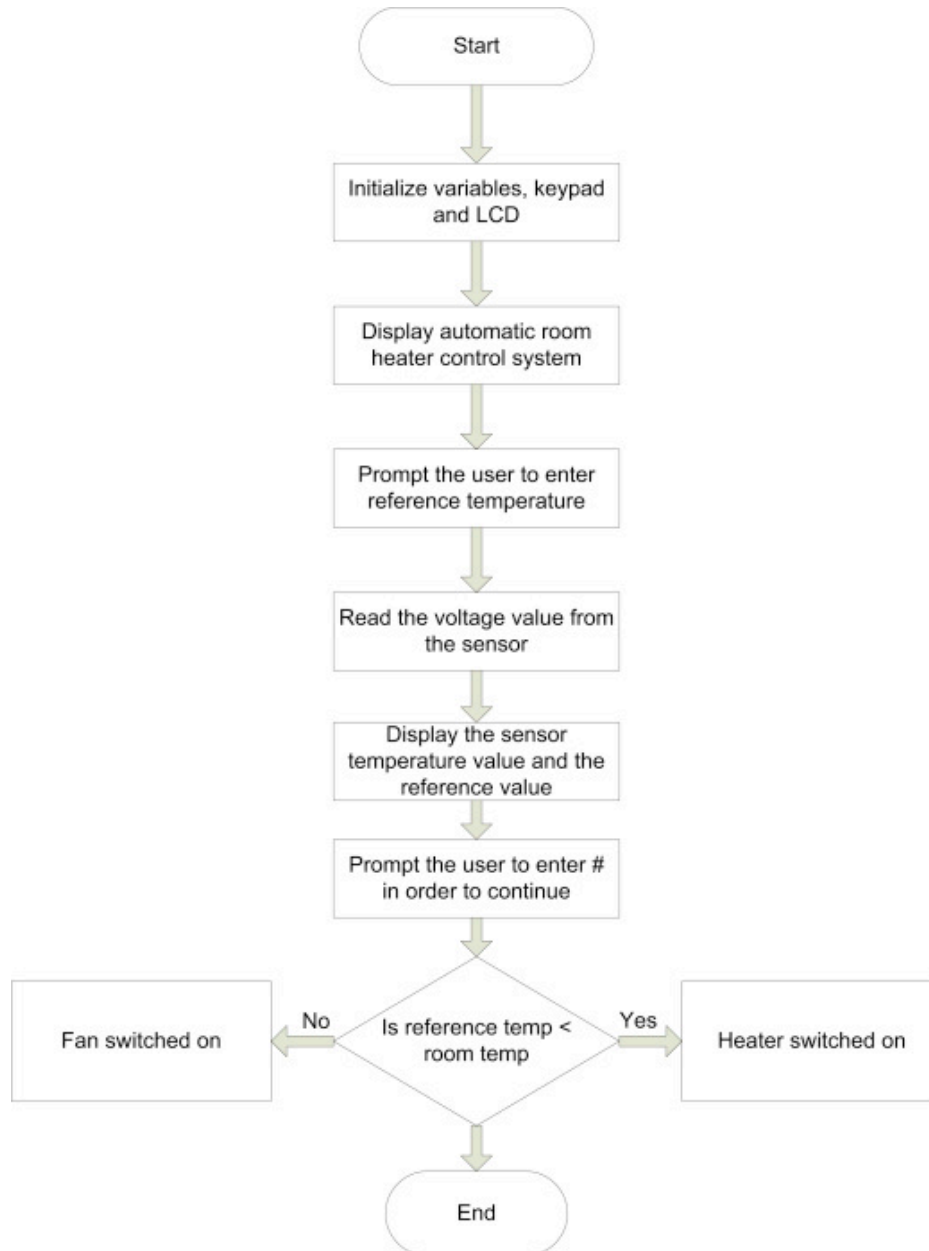

SENSING UNIT

This section of the system uses a temperature sensor(OW24). A temperature sensor is a device that is temperature sensitive, and it responds to changes in temperature. For the calibration of the temperature sensor, a linear modeling approach is used. As it was used as a basic temperature sensor, any change in temperature by 1^o C is converted to 10 mV. The maximum

voltage readout of the temperature sensor was 1V corresponding to 100° C. This was then used as a reference in programming the micro controller. OW24 feeds the micro controller with an analog temperature voltage that is measured from the soil. This analog signal is then converted to digital signal in the micro controller because the micro controller can only interpret digital data. OW24 is connected to PORT A on the micro controller because PORT A is analog input pin by default. Although, the general relationship between the voltages drop at the pin2 of the micro controller gotten from the temperature sensor and the sensed temperature by the OW24 temperature sensor is given by:

$$\text{Temperature } (^{\circ}\text{C}) = \text{Vout} (100^{\circ}\text{C}/\text{Vt})$$

Where Vt is the supply voltage and Vout is the output voltage of the OW24 temperature sensor.

CONTROL/SWITCHING UNIT

The control/switching unit houses the micro controller which receives temperature status from the sensor unit. This unit consists of micro controller, which uses RTC12345A micro controller due To its reduced instruction set computer design. This also makes it code efficient allowing the RTC to run with typically less program memory than its larger competitors such as 3428 based micro controllers. It is also low cost in addition to its high clock speed. Other components and devices in this unit are: two(2) transistors and two(2) relays to switch ON and/or OFF a fan or heater. At first, the user is prompted to input reference temperature that he or she wants to maintain. The temperature sensor will then measure the surrounding temperature and communicates the value to the micro controller. The micro controller reads the temperature every 10s and compares it with the reference value. If the measured value is less than the reference value, the heater will automatically be turned. If the measured value is greater than the reference value, the cooler/fan will be turned ON to cool the room back to reference temperature and turns OFF once it's at that reference point again. The measured room temperature from the Temperature sensor is analog in nature. The micro controller has an in built analog-to-digital (A/D) converter which convert the analog signal into digital signal because the micro controller is a digital device, and can only work with binary numbers. The pseudocode leads to the coding of the micro controller as shown in pseudocode 1: PSEUDOCODE 1

PIC 16F877A PSEUDOCODE

Initialize ports and variables

Read Temp from the analog sensor

Input Reference Temp

Display both the ACTUAL TEMP AND REFERENCE TEMP

COMPARE REF WITH ACTUAL

If Temp Ref is less than actual Temp, Switch ON Heater

If Temp Ref is greater than actual Temp, Switch ON Fan

The micro controller was programmed using C language and the program was compiled using micro C compiler. The code used as starting code before modification. Micro C controller

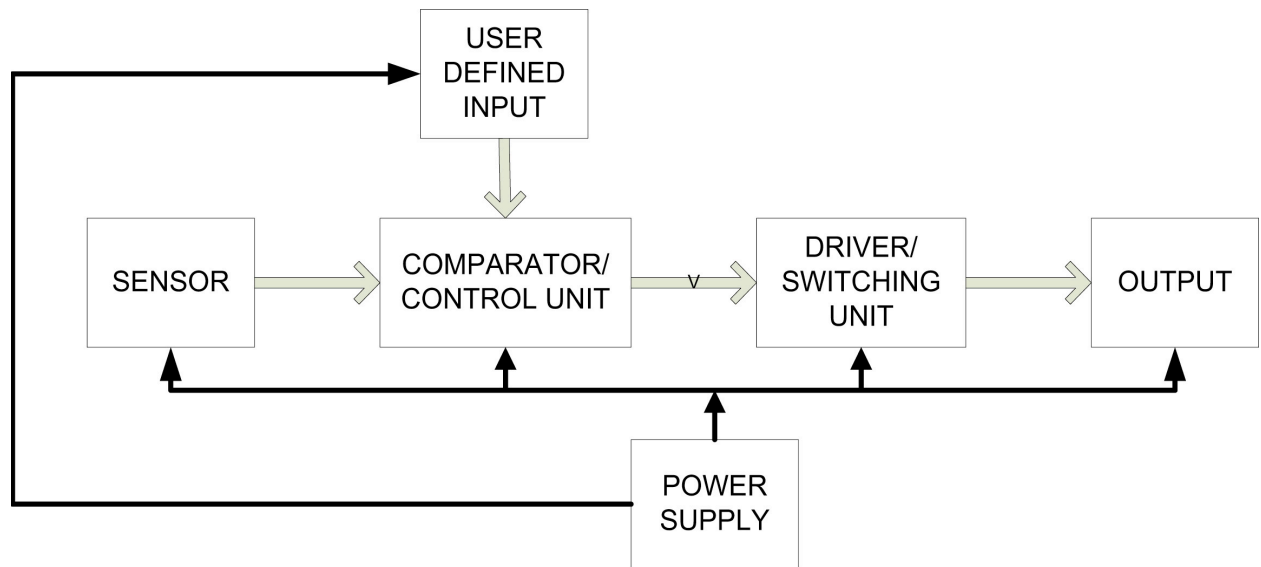

automatically generates hexadecimal file(HEX) which was later exported into the derjan file for simulation. Other aspect of the switching unit is the base bias ink of the transistor.

THE MOISTURE CONTENT DETERMINER

Moisture content affects the processibility, shelf-life, usability and quality of a product. Accurate moisture content determination therefore plays a key role in ensuring quality in many industries including Food, Pharmaceuticals and Chemicals. Furthermore, the maximum permissible moisture content in certain products may be governed by legislation (e.g. national food regulations).

Typically, moisture content is determined via a thermogravimetric approach, i.e. by loss on drying, in which the sample is heated and the weight loss due to evaporation of moisture is recorded. Commonly used moisture analysis technologies are the moisture analyzer and the drying oven in combination with a balance.

THE TIME INTERVAL FOR WATER SYSTEM

Depending on the type of plants in the farm, the application of drip and sprinkler should be carried out to determine the interval. Two kinds of pumps that depend on the type of irrigation are to be tested to, namely the alternating current(A/C) pump for high pressure sprinklers and direct current(D/C) pumps for small pressure sprinkler and deep irrigations. The main part of the automatic system is the real time clock (RTC) SV-2109 and hiroini minimum system, which integrated other supported components such as the LCD viewer and indicator, actuator unit, and AC and DC pump. And sensor of water level for water reservoir. The hiroini minimum system is compact enough to be used as a control center. Agriculture is an intensive use of water,

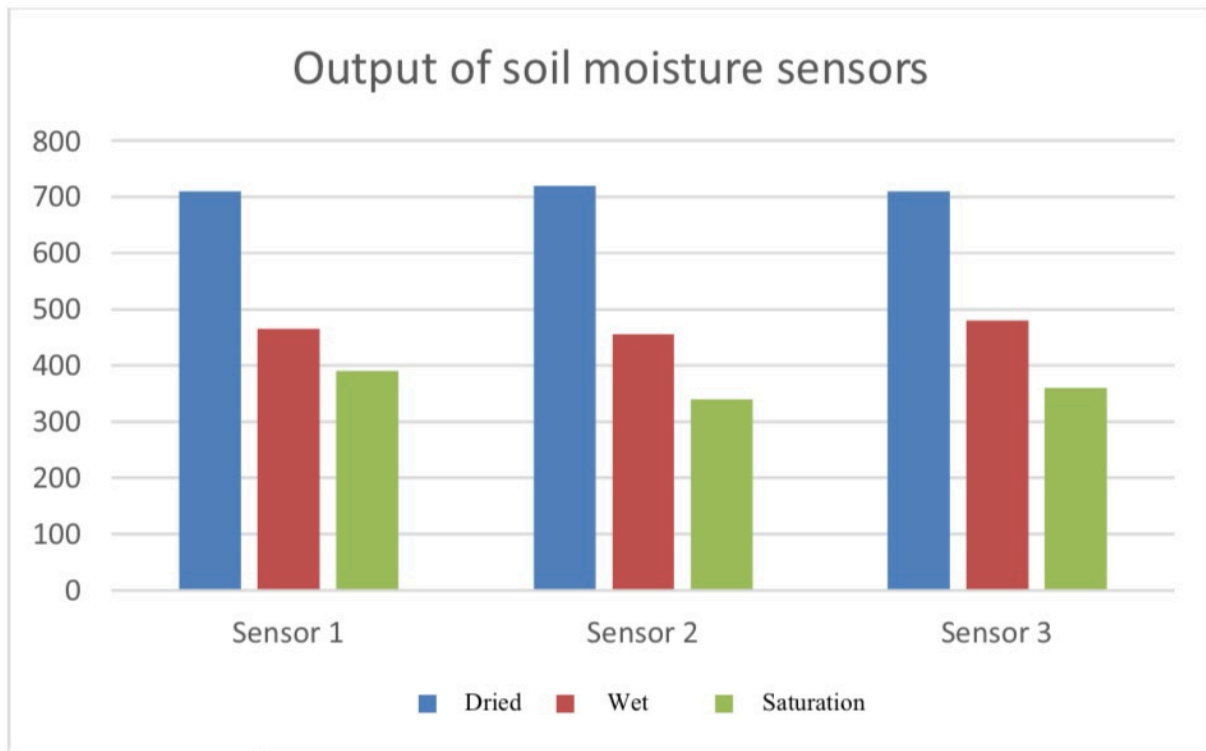

Response of soil moisture sensors to three conditions.

because crop production requires a lot of water. Therefore, it creates need of a system that on one hand saves water and on the other is suitable to produce high yield simultaneously. An automatic watering system requires all the components that control continuously the available water in reservoir and then deliver to the plants at particular time and amount without human intervention and failure. The watering system should perform the following functions: (a) monitor continuously the amount of soil water available to plants, (b) determine if watering is required for the plants based on the information obtained from monitoring the soil moisture, (c) supply exact (or approximate) amount of water required for the plants, (d) discontinue the water supply when the required amount has been given to the plants. Those features are important as the amount of water available for the irrigation system is not infinite, therefore water controlling is essential

The response of the output of soil moisture sensors to soil conditions is shown . It can be seen that in dry conditions the sensor will give a large output, while in wet conditions it will give a small response. In other words, the sensor output value is inversely proportional to the condition of soil moisture. This shows that the sensor has a behavior following the principle of resistance. The tests of watering system were carried out at The Laboratory of Agricultural Machinery and Equipment. The test is carried out by observing the condition of the irrigation pump at set times, during testing, the automatic system can work properly.

Automatic irrigation system built is a simple system, using microcontroller to automate the irrigation and watering of crops. This system does the control of soil moisture in which when particular time and dry soil, it will activate the irrigation system pumping water for watering plants. A 15X4 LCD displays all actions that are taking place and a real Time clock. This system does uses a water level sensor and a moisture sensor to detect the moisture level. A pump is also

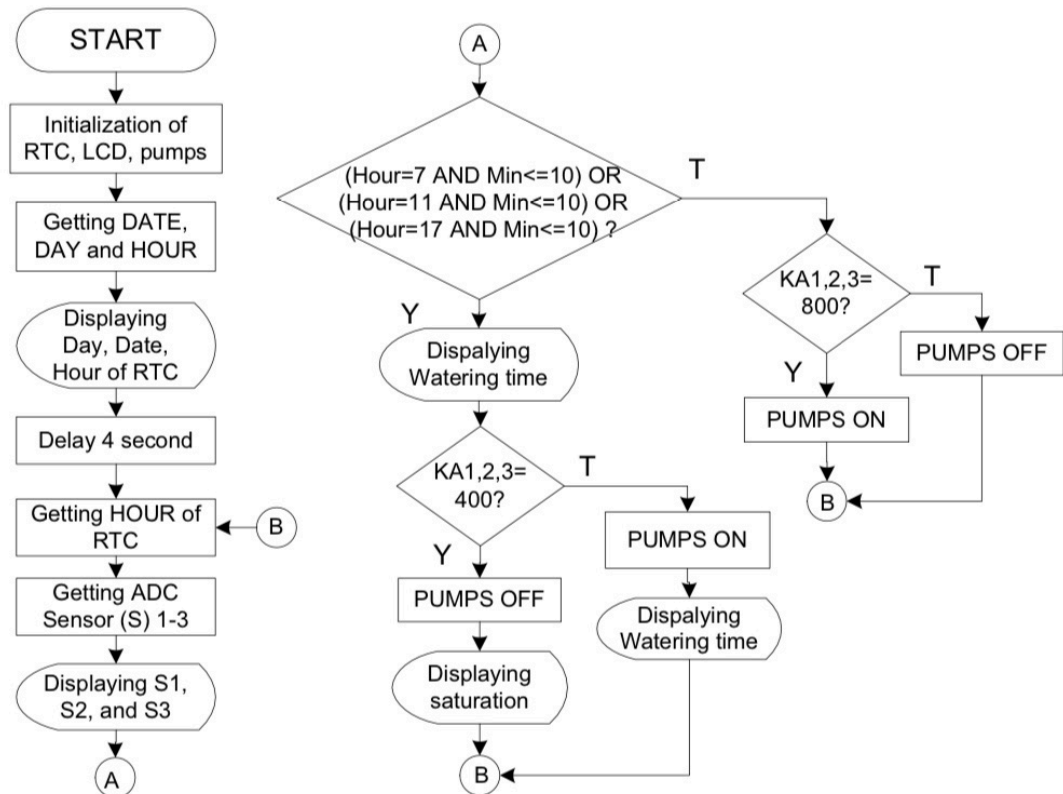

Flowchart of automatic watering control system.

connected which will get on when moisture level falls down and will automatically turn OFF when moisture level will become sufficient. LCD is connected to the microcontroller, which displays current date and time, setting of watering time, and upper and lower moisture levels, current moisture level of soil, and status of pump and watering.

THE PASSWORD

The ability to access the automated farm should be only for the people given access. In order to achieve this, a password is put in place to prevent unauthorized access. Having explored the different means in which security is compromised, using cryptography to encrypt the password is the best solution for this requirement. Cryptography will let you transform a piece of meaningful text into non-meaningful data. There are basically three different kinds of cryptography methods. Symmetric and Asymmetric algorithms are both used as keys to encrypt and decrypt data

Q3. Support your answer with a flowchart and an algorithm

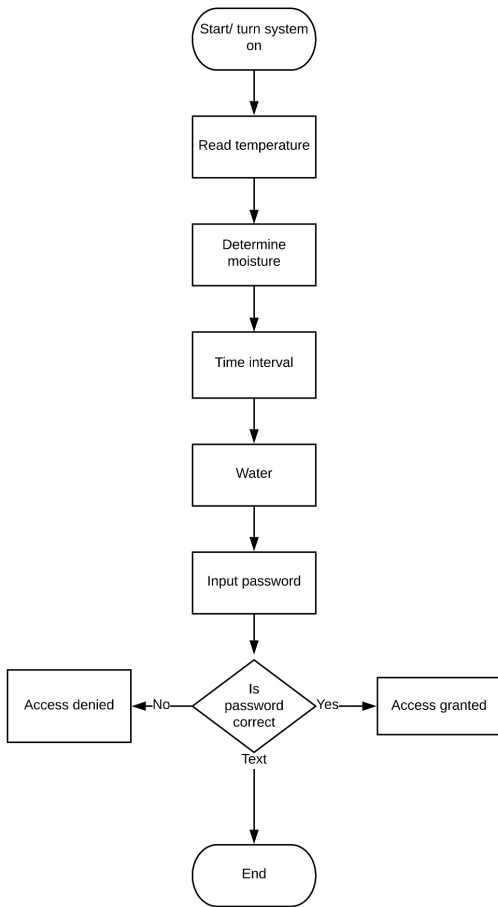

Q4. Draw the top-down or bottom up approach of the application.

