

5/10/17

UNIT 5 GOVERNORS

Structure

- 5.1 Introduction
 - Objectives
- 5.2 Classification of Governors
- 5.3 Gravity Controlled Centrifugal Governors
 - 5.3.1 Watt Governor
 - 5.3.2 Porter Governor
- 5.4 Spring Controlled Centrifugal Governors
- 5.5 Governor Effort and Power
- 5.6 Characteristics of Governors
- 5.7 Controlling Force and Stability of Spring Controlled Governors
- 5.8 Insensitiveness in the Governors
- 5.9 Summary
- 5.10 Key Words
- 5.11 Answers to SAQs

5.1 INTRODUCTION

In the last unit, you studied flywheel which minimises fluctuations of speed within the cycle but it cannot minimise fluctuations due to load variation. This means flywheel does not exercise any control over mean speed of the engine. To minimise fluctuations in the mean speed which may occur due to load variation, governor is used. The governor has no influence over cyclic speed fluctuations but it controls the mean speed over a long period during which load on the engine may vary.

When there is change in load, variation in speed also takes place then governor operates a regulatory control and adjusts the fuel supply to maintain the mean speed nearly constant. Therefore, the governor automatically regulates through linkages, the energy supply to the engine as demanded by variation of load so that the engine speed is maintained nearly constant.

Figure 5.1 shows an illustrative sketch of a governor along with linkages which regulates the supply to the engine. The governor shaft is rotated by the engine. If load on the engine increases the engine speed tends to reduce, as a result of which governor balls move inwards. This causes sleeve to move downwards and this movement is transmitted to the valve through linkages to increase the opening and, thereby, to increase the supply.

On the other hand, reduction in the load increases engine speed. As a result of which the governor balls try to fly outwards. This causes an upward movement of the sleeve and it reduces the supply. Thus, the energy input (fuel supply in IC engines, steam in steam turbines, water in hydraulic turbines) is adjusted to the new load on the engine. Thus the governor senses the change in speed and then regulates the supply. Due to this type of action it is simple example of a mechanical feedback control system which senses the output and regulates input accordingly.

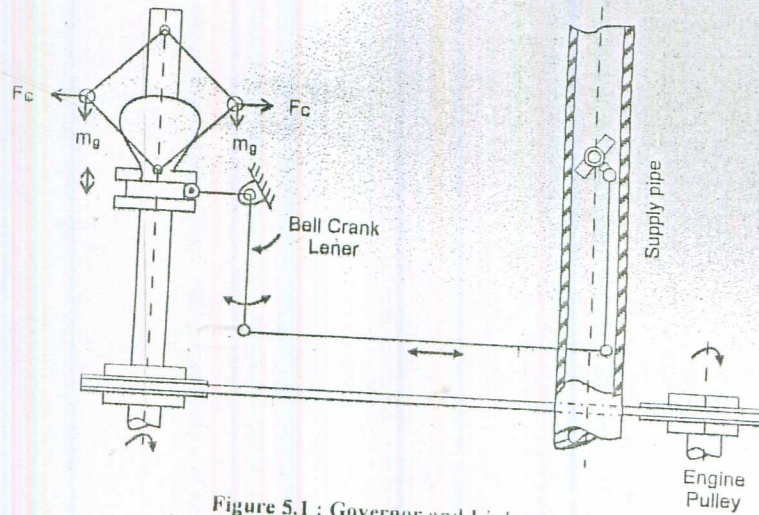

Figure 5.1 : Governor and Linkages

Objectives

After studying this unit, you should be able to

- classify governors,
- analyse different type of governors,
- know characteristics of governors,
- know stability of spring controlled governors, and
- compare different type of governors.

5.2 CLASSIFICATION OF GOVERNORS

The broad classification of governor can be made depending on their operation.

- (a) Centrifugal governors
- (b) Inertia and flywheel governors
- (c) Pickering governors.

Centrifugal Governors

In these governors, the change in centrifugal forces of the rotating masses due to change in the speed of the engine is utilised for movement of the governor sleeve. One of this type of governors is shown in Figure 5.1. These governors are commonly used because of simplicity in operation.

Inertia and Flywheel Governors

In these governors, the inertia forces caused by the angular acceleration of the engine shaft or flywheel by change in speed are utilised for the movement of the balls. The movement of the balls is due to the rate of change of speed in stead of change in speed itself as in case of centrifugal governors. Thus, these governors are more sensitive than centrifugal governors.

Pickering Governors

This type of governor is used for driving a gramophone. As compared to the centrifugal governors, the sleeve movement is very small. It controls the speed by dissipating the excess kinetic energy. It is very simple in construction and can be used for a small machine.

5.2.1 Types of Centrifugal Governors

Depending on the construction these governors are of two types :

- (a) Gravity controlled centrifugal governors, and
- (b) Spring controlled centrifugal governors.

Gravity Controlled Centrifugal Governors

In this type of governors there is gravity force due to weight on the sleeve or weight of sleeve itself which controls movement of the sleeve. These governors are comparatively larger in size.

Spring Controlled Centrifugal Governors

In these governors, a helical spring or several springs are utilised to control the movement of sleeve or balls. These governors are comparatively smaller in size.

Governors

comparatively ^{large} size
There is gravity force due to weight
sleeve or gravity force controls movement of the sleeve

comparatively small in size
There is none
helical springs are used to control the movement of the sleeves

SAQ 1

- (a) Compare flywheel with governor.
- (b) Which type of control the governor system is?
- (c) Compare centrifugal governors with inertia governors.

5.3 GRAVITY CONTROLLED CENTRIFUGAL GOVERNORS

There are three commonly used gravity controlled centrifugal governors :

- (a) Watt governor
- (b) Porter governor
- (c) Proell governor

Watt governor does not carry dead weight at the sleeve. Porter governor and proell governor have heavy dead weight at the sleeve. In porter governor balls are placed at the junction of upper and lower arms. In case of proell governor the balls are placed at the extension of lower arms. The sensitiveness of watt governor is poor at high speed and this limits its field of application. Porter governor is more sensitive than watt governor. The proell governor is most sensitive out of these three.

5.3.1 Watt Governor

This governor was used by James Watt in his steam engine. The spindle is driven by the output shaft of the prime mover. The balls are mounted at the junction of the two arms. The upper arms are connected to the spindle and lower arms are connected to the sleeve as shown in Figure 5.2(a).

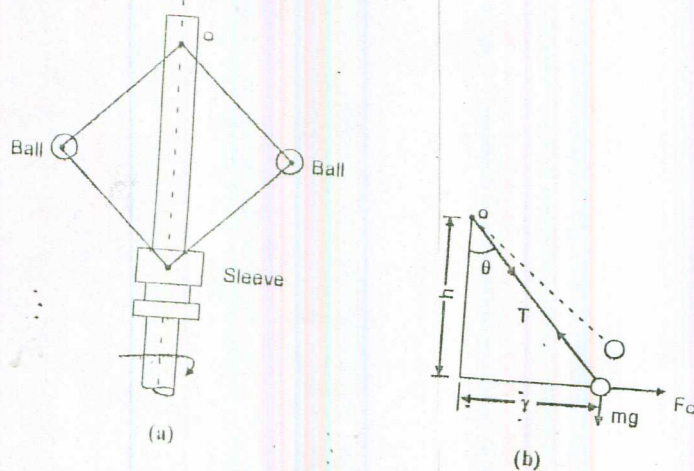

Figure 5.2 : Watt Governor

We ignore mass of the sleeve, upper and lower arms for simplicity of analysis. We can ignore the friction also. The ball is subjected to the three forces which are centrifugal force (F_C), weight (mg) and tension by upper arm (T). Taking moment about point O (intersection of arm and spindle axis), we get

$$F_C h - mg r = 0$$

Since,

$$F_C = mr \omega^2$$

$$mr \omega^2 h - mg r = 0$$

or

$$\omega^2 = \frac{g}{h} \quad \dots (5.1)$$

$$\omega = \frac{2\pi N}{60}$$

$$h = \frac{g \times 3600}{4\pi^2 N^2} = \frac{894.56}{N^2} \quad \dots (5.2)$$

where ' N ' is in rpm.

Figure 5.3 shows a graph between height ' h ' and speed ' N ' in rpm. At high speed the change in height h is very small which indicates that the sensitiveness of the governor is very poor at high speeds because of flatness of the curve at higher speeds.

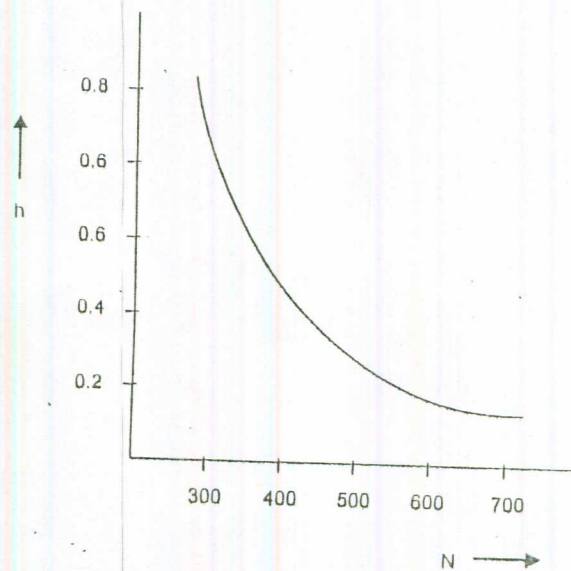

Figure 5.3 : Graph between Height and Speed

SAQ 2

Why watt governor is very rarely used? Give reasons.

5.3.2 Porter Governor

A schematic diagram of the porter governor is shown in Figure 5.4(a). There are two sets of arms. The top arms OA and OB connect balls to the hinge O . The hinge may be on the spindle or slightly away. The lower arms support dead weight and connect balls also. All of them rotate with the spindle. We can consider one-half of governor for equilibrium.

Let w be the weight of the ball,
 T_1 and T_2 be tension in upper and lower arms, respectively,
 F_c be the centrifugal force,
 r be the radius of rotation of the ball from axis, and
 I is the instantaneous centre of the lower arm.

Taking moment of all forces acting on the ball about I and neglecting friction at the sleeve, we get

$$F_c \times AD - w \times ID - \frac{W}{2} IC = 0$$

or
$$F_c = \frac{wID}{AD} + \frac{W}{2} \left(\frac{ID + DC}{AD} \right)$$

or
$$F_c = w \tan \alpha + \frac{W}{2} (\tan \alpha + \tan \beta)$$

$$F_c = \frac{w}{g} \omega^2 r$$

$$\frac{w}{g} \omega^2 r = w \tan \alpha \left\{ 1 + \frac{W}{2w} \left(1 + \frac{\tan \beta}{\tan \alpha} \right) \right\}$$

or
$$\omega^2 = \frac{g}{r} \tan \alpha \left\{ 1 + \frac{W}{2w} (1 + K) \right\} \dots (5.3)$$

where
$$K = \frac{\tan \beta}{\tan \alpha}$$

$$\tan \alpha = \frac{r}{h}$$

$$\omega^2 = \frac{g}{h} \left\{ 1 + \frac{W}{2w} (1 + K) \right\} \dots (5.4)$$

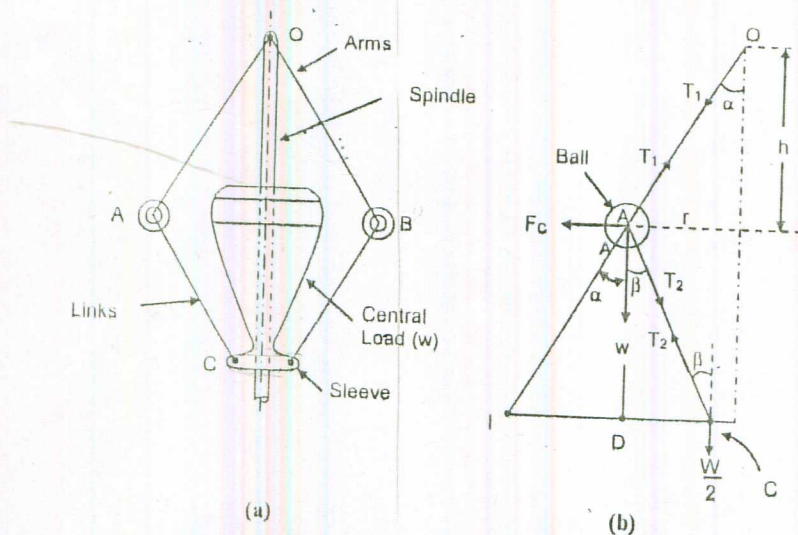

Figure 5.4 : Porter Governor

If friction at the sleeve is f , the force at the sleeve should be replaced by $W + f$ for rising and by $(W - f)$ for falling speed as friction opposes the motion of sleeve. Therefore, if the friction at the sleeve is to be considered, W should be replaced by $(W \pm f)$. The expression in Eq. (5.4) becomes

$$\omega^2 = \frac{g}{h} \left\{ 1 + \frac{(W \pm f)}{2w} (1 + K) \right\} \quad \dots (5.5)$$

SAQ 3

In which respect Porter governor is better than Watt governor?

5.4 SPRING CONTROLLED CENTRIFUGAL GOVERNORS

In these governors springs are used to counteract the centrifugal force. They can be designed to operate at high speeds. They are comparatively smaller in size. Their speed range can be changed by changing the initial setting of the spring. They can work with inclined axis of rotation also. These governors may be very suitable for IC engines, etc.

The most commonly used spring controlled centrifugal governors are :

- (a) Hartnell governor
- (b) Wilson-Hartnell governor
- (c) Hartung governor

5.4.1 Hartnell Governor

The Hartnell governor is shown in Figure 5.5. The two bell crank levers have been provided which can have rotating motion about fulcrums O and O' . One end of each bell crank lever carries a ball and a roller at the end of other arm. The rollers make contact with the sleeve. The frame is connected to the spindle. A helical spring is mounted around the spindle between frame and sleeve. With the rotation of the spindle, all these parts rotate.

With the increase of speed, the radius of rotation of the balls increases and the rollers lift the sleeve against the spring force. With the decrease in speed, the sleeve moves downwards. The movement of the sleeve are transferred to the throttle of the engine through linkages.

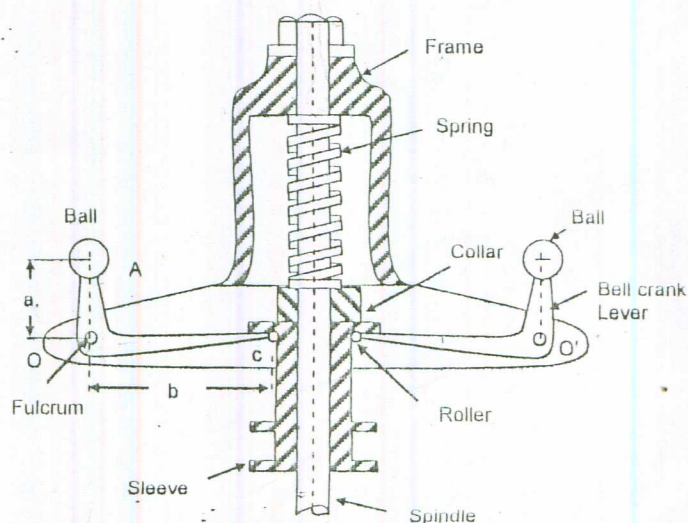

Figure 5.5 : Hartnell Governor

- Let r_1 = Minimum radius of rotation of ball centre from spindle axis, in m,
 r_2 = Maximum radius of rotation of ball centre from spindle axis, in m,
 S_1 = Spring force exerted on sleeve at minimum radius, in N,
 S_2 = Spring force exerted on sleeve at maximum radius, in N,
 m = Mass of each ball, in kg,
 M = Mass of sleeve, in kg,
 N_1 = Minimum speed of governor at minimum radius, in rpm,
 N_2 = Maximum speed of governor at maximum radius, in rpm,

ω_1 and ω_2 = Corresponding minimum and maximum angular velocities, in r/s,

$(F_C)_1$ = Centrifugal force corresponding to minimum speed = $m \times \omega_1^2 \times r_1$,

$(F_C)_2$ = Centrifugal force corresponding to maximum speed = $m \times \omega_2^2 \times r_2$,

s = Stiffness of spring or the force required to compress the spring by one m,

r = Distance of fulcrum O from the governor axis or radius of rotation,

a = Length of ball arm of bell-crank lever, i.e. distance OA , and

b = Length of sleeve arm of bell-crank lever, i.e. distance OC .

Considering the position of the ball at radius ' r_1 ', as shown in Figure 5.6(a) and taking moments of all the forces about O

$$M_O = (F_C)_1 a \cos \theta_1 - mg a \sin \theta_1 - \frac{(Mg + S_1)}{2} b \cos \theta_1 = 0$$

or $(F_C)_1 = mg \tan \theta_1 + \frac{(Mg + S_1)}{2} \left(\frac{b}{a} \right) \dots (5.9)$

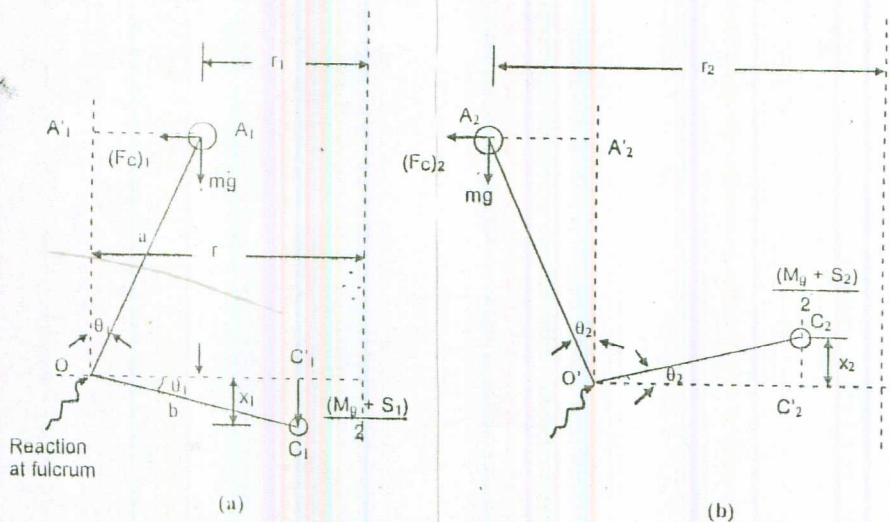

Figure 5.6

Considering the position of the ball at radius ' r_2 ' as shown in Figure 5.6(b) and taking the moments of all the forces about O'

$$\therefore M'_O = (F_C)_2 a \cos \theta_2 + mg a \sin \theta_2 - \frac{(Mg + S_2)}{2} b \cos \theta_2$$

or $(F_C)_2 = \frac{(Mg + S_2)}{2} \left(\frac{b}{a} \right) - mg \tan \theta_2 \dots (5.10)$

7

If θ_1 and θ_2 are very small and mass of the ball is negligible as compared to the spring force, the terms $mg \tan \theta_1$ and $mg \tan \theta_2$ may be ignored.

$$(F_C)_1 = \frac{(Mg + S_1)}{2} \left(\frac{b}{a} \right) \quad \dots (5.11)$$

and $(F_C)_2 = \frac{(Mg + S_2)}{2} \left(\frac{b}{a} \right) \quad \dots (5.12)$

$$\therefore (F_C)_2 - (F_C)_1 = \frac{(S_2 - S_1)}{2} \left(\frac{b}{a} \right)$$

$$\begin{aligned} \text{Total lift} &= (x_1 + x_2) \square (b \theta_1 + b \theta_2) \\ &= b (\theta_1 + \theta_2) \end{aligned}$$

$$= b \left(\frac{(r - r_1)}{a} + \frac{(r_2 - r)}{a} \right) = \frac{b}{a} (r_2 - r_1)$$

$$S_2 - S_1 = \text{Total lift} \times s = \frac{b}{a} (r_2 - r_1) s$$

$$\therefore (F_C)_2 - (F_C)_1 = \left(\frac{b}{a} \right)^2 \frac{(r_2 - r_1)}{2} s$$

$$\text{or stiffness of spring 's'} = 2 \left(\frac{a}{b} \right)^2 \frac{(F_C)_2 - (F_C)_1}{(r_2 - r_1)} \quad \dots (5.13)$$

For ball radius 'r'

$$s = 2 \left(\frac{a}{b} \right)^2 \frac{F_C - (F_C)_1}{r - r_1} = 2 \left(\frac{a}{b} \right)^2 \left\{ \frac{(F_C)_2 - (F_C)_1}{(r_2 - r_1)} \right\}$$

$$\therefore F_C = (F_C)_1 + \frac{(r - r_1)}{(r_2 - r_1)} \{ (F_C)_2 - (F_C)_1 \} \quad \dots (5.14)$$

SAQ 4

For IC engines, which type of governor you will prefer whether dead weight type or spring controlled type? Give reasons.

5.5 GOVERNOR EFFORT AND POWER

Governor effort and power can be used to compare the effectiveness of different type of governors.

Governor Effort

It is defined as the mean force exerted on the sleeve during a given change in speed.

When governor speed is constant the net force at the sleeve is zero. When governor speed increases, there will be a net force on the sleeve to move it upwards and sleeve starts moving to the new equilibrium position where net force becomes zero.

Governor Power

It is defined as the work done at the sleeve for a given change in speed. Therefore,

$$\text{Power of governor} = \text{Governor effort} \times \text{Displacement of sleeve}$$

5.5.1 Determination of Governor Effort and Power

The effort and power of a Porter governor has been determined. The same principle can be used for any other type of governor also.

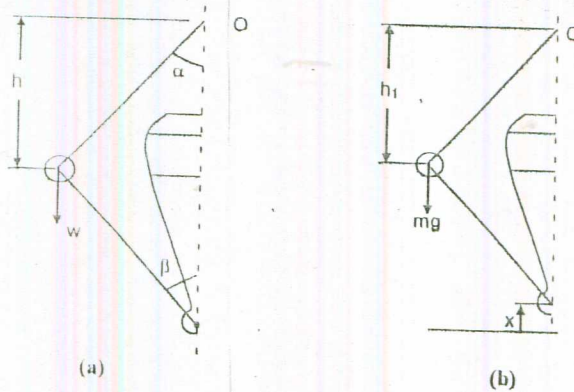

Figure 5.7

Figure 5.7 shows the two positions of a Porter governor.

Let N = Equilibrium speed corresponding to configuration shown in Figure 5.7(a),

W = Weight of sleeve in N,

h = Height of governor corresponding to speed N , and

c = A factor which when multiplied to equilibrium speed, gives the increase in speed.

\therefore Increased speed = Equilibrium speed + Increase of speed,

$$= N + c \cdot N = (1 + c) N, \text{ and} \quad \dots (5.15)$$

h_1 = Height of governor corresponding to increased speed $(1 + c) N$.

The equilibrium position of the governor for the increased speed is shown in Figure 5.7(b). In order to prevent the sleeve from rising when the increase of speed takes place, a downward force will have to be exerted on the sleeve.

Let W_1 = New weight of sleeve so that the rising of sleeve is prevented when the speed is $(1 + c) N$. This means that W_1 is the weight of sleeve when height of governor is h .

\therefore Downward force to be applied when the rising of sleeve is to be prevented when speed increases from N to $(1 + c) N = W_1 - W$.

When speed is N rpm and let the angles α and β are equal so that $K = 1$, the height h is given by equation

$$h = \left(\frac{w + W}{w} \right) \times \frac{g}{\left(\frac{2\pi N}{60} \right)^2} \quad \dots (5.16)$$

If the speed increases to $(1 + c) N$ and height remains the same by increasing the load on sleeve

$$h = \left(\frac{w + W_1}{w} \right) \times \frac{g}{\left(\frac{2\pi (1 + c) N}{60} \right)^2} \quad \dots (5.17)$$

Equating the two values of h given by above equations, we get

$$w + W = \frac{(w + W_1)}{(1 + c)^2}$$

$$(w + W)(1 + c)^2 = w + W_1$$

$$W_1 = (w + W)(1 + c)^2 - w$$

$$(W_1 - W) = (w + W)(1 + c)^2 - (w + W)$$

$$= (w + W) \{(1 + c)^2 - 1\}$$

$$\square 2c(w + W) \text{ If } c \text{ is very small} \quad \dots (5.18)$$

But $W_1 - W$ is the downward force which must be applied in order to prevent the sleeve from rising when the increase of speed takes place. This is also the force exerted by the governor on the sleeve when the speed changes from N to $(1 + c)N$. As the sleeve rises to the new equilibrium position as shown in Figure 5.7(b), this force gradually diminishes to zero. The mean force P exerted on the sleeve during the change of speed from N to $(1 + c)N$ is therefore given by

$$P = \frac{W_1 - W}{2} \square c(w + W) \quad \dots (5.19)$$

This is the governor effort.

If weight on the sleeve is not increased

$$h_1 = \left(\frac{w + W}{w} \right) \frac{g}{\left\{ \frac{2\pi(1 + c)N}{60} \right\}^2} \quad \dots (5.20)$$

$$h - h_1 = 2x$$

$$\frac{h}{h_1} = (1 + c)^2$$

$$\frac{h}{h_1} - 1 = (1 + c)^2 - 1 \square 2c$$

or
$$\frac{h - h_1}{h_1} = 2c$$

or
$$\frac{2x}{h_1} = 2c$$

or
$$x = c h_1$$

$$\therefore \text{Governor power} = Px = c^2 h_1 (w + W). \quad \dots (5.21)$$

5.6 CHARACTERISTICS OF GOVERNORS

Different governors can be compared on the basis of following characteristics :

Stability

A governor is said to be stable when there is one radius of rotation of the balls for each speed which is within the speed range of the governor.

Sensitiveness

The sensitiveness can be defined under the two situations :

- (a) When the governor is considered as a single entity.
 (b) When the governor is fitted in the prime mover and it is treated as part of prime mover.
- (a) A governor is said to be sensitive when there is larger displacement of the sleeve due to a fractional change in speed. Smaller the change in speed of the governor for a given displacement of the sleeve, the governor will be more sensitive.

$$\therefore \text{Sensitiveness} = \frac{N}{N_1 - N_2} \quad \dots (5.22)$$

- (b) The smaller the change in speed from no load to the full load, the more sensitive the governor will be. According to this definition, the sensitiveness of the governor shall be determined by the ratio of speed range to the mean speed. The smaller the ratio more sensitive the governor will be

$$\therefore \text{Sensitiveness} = \frac{N_2 - N_1}{N} = \frac{2(N_2 - N_1)}{(N_2 + N_1)} \quad \dots (5.23)$$

where $N_2 - N_1$ = Speed range from no load to full load.

Isochronism

A governor is said to be isochronous if equilibrium speed is constant for all the radii of rotation in the working range. Therefore, for an isochronous governor the speed range is zero and this type of governor shall maintain constant speed.

Hunting

Whenever there is change in speed due to the change in load on the engine, the sleeve moves towards the new position but because of inertia it overshoots the desired position. Sleeve then moves back but again overshoots the desired position due to inertia. This results in setting up of oscillations in engine speed. If the frequency of fluctuations in engine speed coincides with the natural frequency of oscillations of the governor, this results in increase of amplitude of oscillations due to resonance. The governor, then, tends to intensify the speed variation instead of controlling it. This phenomenon is known as hunting of the governor. Higher the sensitiveness of the governor, the problem of hunting becomes more acute.

5.7 CONTROLLING FORCE AND STABILITY OF SPRING CONTROLLED GOVERNORS

The resultant external force which controls the movement of the ball and acts along the radial line towards the axis is called controlling force. This force acts at the centre of the ball. It is equal and acts opposite to the direction of centrifugal force.

The controlling force $F = m \omega^2 r$.

$$\text{Or} \quad \frac{F}{r} = m \left(\frac{2\pi N}{60} \right)^2$$

For controlling force diagram in which 'F' is plotted against radius 'r', $\frac{F}{r}$ represents slope of the curve.

$$\text{i.e.} \quad \frac{F}{r} = \tan \phi \propto N^2 \quad \dots (5.24)$$

Therefore, for a stable governor slope in controlling force diagram should increase with the increase in speed.

Stability of Spring-controlled Governors

Figure 5.8 shows the controlling force curves for stable, isochronous and unstable spring controlled governors. The controlling force curve is approximately straight line for spring controlled governors. As controlling force curve represents the variation of controlling force 'F' with radius of rotation 'r', hence, straight line equation can be,

$$F = ar + b; \quad F = ar \quad \text{or} \quad F = ar - b \quad \dots (5.25)$$

where a and b are constants. In the above equation b may be +ve, or -ve or zero.

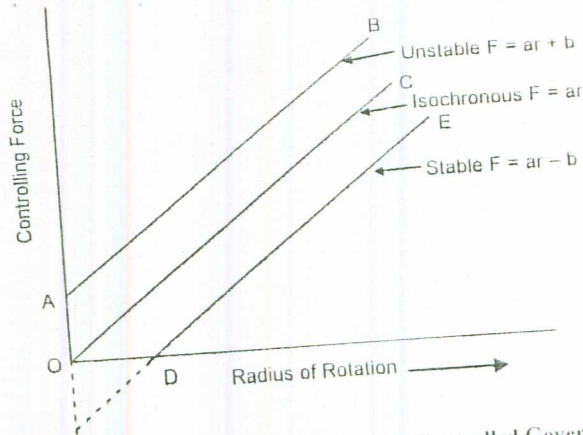

Figure 5.8 : Stability of Spring Controlled Governors

These three cases are as follows :

- (a) We know that for a stable governor, the ratio $\frac{F}{r}$ must increase as r increases. Hence the controlling force curve DE for a stable governor must intersect the controlling force axis (i.e. y -axis) below the origin, when produced. Then the equation of the curve will be of the form

$$F = a \cdot r - b \quad \text{or} \quad \frac{F}{r} = a - \frac{b}{r} \quad \dots (5.26)$$

As r increases $\frac{F}{r}$ increase and thereby $\tan \phi$ increases. Therefore, this equation represents stable governor.

- (b) If b in the above equation is zero then the controlling force curve OC will pass through the origin. The ratio $\frac{F}{r}$ will be constant for all radius of rotation and hence the governor will become isochronous. Hence for isochronous, the equation will be

$$F = ar \quad \text{or} \quad \frac{F}{r} = a = \text{constant} \quad \dots (5.27)$$

- (c) If b is positive, then controlling force curve AB will intersect the controlling force axis (i.e. y -axis) above the origin. The equation of the curve will be

$$F = ar + b \quad \text{or} \quad \frac{F}{r} = a + \frac{b}{r} \quad \dots (5.28)$$

As r increases, speed increases, $\frac{F}{r}$ or $\tan \phi$ reduces. Hence this equation cannot represent stable governor but unstable governor.

5.8 INSENSITIVENESS IN THE GOVERNORS

The friction force at the sleeve gives rise to the insensitiveness in the governor. At any given radius there will be two different speeds one being when sleeve moves up and other when sleeve moves down. Figure 5.9 shows the controlling force diagram for such a governor.

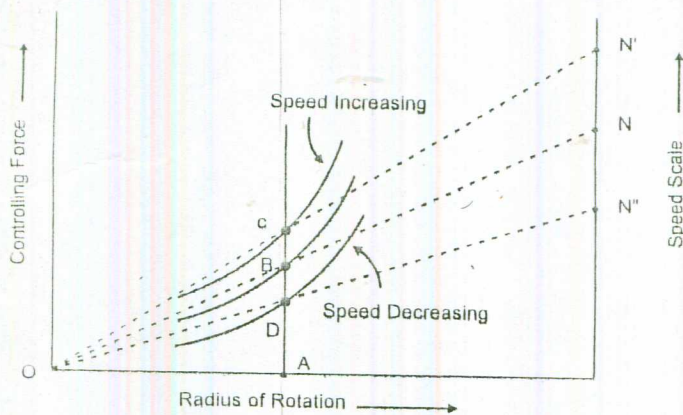

Figure 5.9 : Insensitiveness in the Governors

The corresponding three values of speeds for the same radius OA are :

- The speed N when there is no friction.
- The speed N' when speed is increasing or sleeve is on the verge of moving up, and
- The speed N'' when speed is decreasing or sleeve on the verge of moving down.

This means that, when radius is OA , the speed of rotation may vary between the limits N'' and N' , without causing any displacement of the governor sleeve. The governor is said to be insensitive over this range of speed. Therefore,

$$\therefore \text{Coefficient of insensitiveness} = \left(\frac{N' - N''}{N} \right) \quad \dots (5.29)$$

Example 5.1

The arms of a Porter governor are 25 cm long and pivoted on the governor axis. The mass of each ball is 5 kg and mass on central load of the sleeve is 30 kg. The radius of rotation of balls is 15 cm when the sleeve begins to rise and reaches a value of 20 cm for the maximum speed. Determine speed range.

Solution

Given data : Ball weight ' w ' = 5 g N

Central load ' W ' = 30 g N

Arm length ' l ' = 25 cm = 0.25 m

Minimum radius ' r_1 ' = 15 cm = 0.15 m

Maximum radius ' r_2 ' = 20 cm = 0.2 m

$$\text{Height } 'h_1' = \sqrt{l^2 - r_1^2} = \sqrt{0.25^2 - 0.15^2} = 0.2 \text{ m}$$

For $k = 1$.

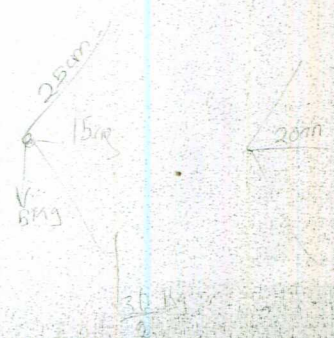

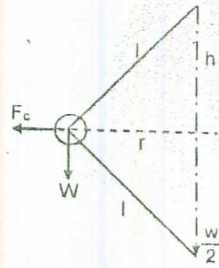

Figure 5.10 : Figure for Example 5.1

Substituting values in Eq. (5.4)

$$\omega_1^2 = \frac{g}{0.2} \left\{ 1 + \frac{W}{2w} (1 + 1) \right\}$$

$$= \frac{9.81}{0.2} \left\{ 1 + \frac{30g}{5g} \right\}$$

$$\omega_1 = 18.5297 \text{ r/s or } N_1 = 176.9 \text{ rpm}$$

$$\text{Height } h_2 = \sqrt{0.25^2 - 0.2^2} = 0.15 \text{ m}$$

$$\omega_2^2 = \frac{9.81}{0.15} \left\{ 1 + \frac{30g}{5g} \right\}$$

$$\omega_2 = 29.396 \text{ r/s or } N_2 = 204.32 \text{ rpm}$$

$$\text{Speed range} = N_2 - N_1 = 204.32 - 176.9 = 27.42 \text{ rpm.}$$

Example 5.2

In a Hartnell governor the radius of rotation is 7 cm when speed is 500 rpm. At this speed, ball arm is normal and sleeve is at mid position. The sleeve movement is 2 cm with $\pm 5\%$ of change in speed. The mass of sleeve is 6 kg and friction is equivalent to 25 N at the sleeve. The mass of the ball is 2 kg. If ball arm and sleeve arms are equal, find,

- (a) Spring rate,
- (b) Initial compression in the spring, and
- (c) Governor effort and power for 1% change in the speed if there is no friction.

Solution

Sleeve mass ' M ' = 6 kg

Friction force ' f ' = 25 N

Ball mass ' m ' = 2 kg

$$\therefore a = b$$

Minimum radius $r_1 = 7 \text{ cm} - 1 = 6 \text{ cm}$

Maximum radius $r_2 = 7 \text{ cm} + 1 = 8 \text{ cm}$

$$\omega = \frac{2\pi \times 500}{60} = 52.36 \text{ r/s}$$

Maximum speed = $1.05 \omega = 1.05 \times 52.36 = 54.98 \text{ r/s}$

Minimum speed = $0.95 \omega = 0.95 \times 52.36 = 49.74 \text{ r/s}$

Neglecting the effect of obliquity of arms.

$2.02 + 52.36$
 $52.36 - 2.02$

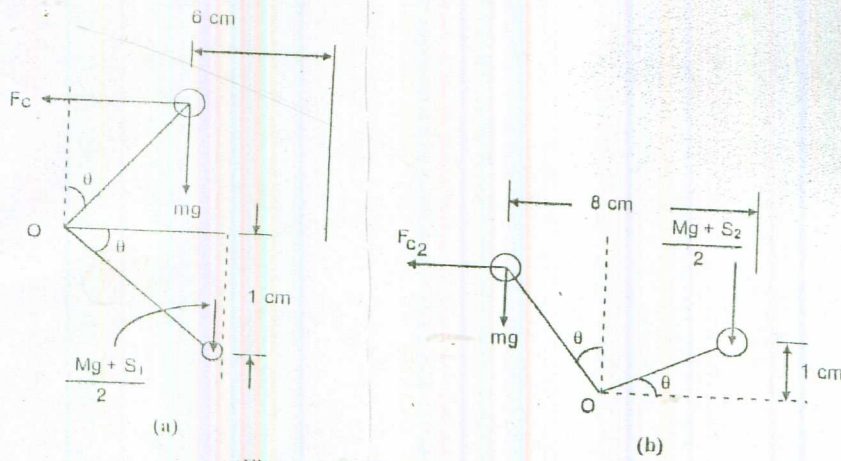

Figure 5.11 : Figure for Example 5.2

At Minimum Radius

$$F_{C1} \times a = b \left(\frac{Mg + S_1 - f}{2} \right) \text{ or } 2F_{C1} = Mg + S_1 - f$$

$$F_{C1} = m \omega_1^2 r_1$$

$$\therefore 2 \times (49.74)^2 \times 0.06 \times 2 = 6g + S_1 - 25$$

$$593.78 = 58.86 + S_1 - 25$$

$$\text{Or } S_1 = 559.92 \text{ N}$$

At Maximum Radius

$$2F_{C2} = Mg + S_2 + f$$

$$F_{C2} = m \omega_2^2 r_2$$

$$\therefore 2 \times (54.98)^2 \times 0.08 \times 2 = 6g + S_2 + 25$$

$$\text{Or } S_2 = 883.44 \text{ N}$$

$$\therefore \text{Stiffness 's'} = \frac{S_2 - S_1}{x} = \frac{883.44 - 559.92}{0.02}$$

$$\text{Or } s = 16175.81 \text{ N/m}$$

$$\text{Initial compression} = S_1 = \frac{559.92}{16175.81} = 0.035 \text{ m or } 3.5 \text{ cm}$$

Governor Effort and Power

$$F_C = \frac{Mg + S_2 \pm f}{2}$$

$$\therefore \text{Increased speed} = 1.01 \omega = 1.01 \times 52.36 = 52.88 \text{ r/s}$$

$$\text{At } r = 0.07; 2 \times 2 \times (52.36)^2 \times 0.07 = 6g + S$$

$$\text{At increased speed, } 2 \times 2 \times (52.88)^2 \times 0.07 = 6g + 2P + S$$

where P is governor effort.

$$\frac{a}{x} = \frac{h_1}{y}$$

Since $x = y$

$$a_1 = h_1$$

$$a_1 = \frac{h_1}{y} = \frac{h_1}{x}$$

$$\frac{a_1}{x} = \frac{h_1}{y}$$

$$a_1 = h_1$$

$$0.524 + 52.36$$

$$2P = hP$$

$$\therefore 2P = 2 \times 2 \times 0.07 \{ (52.88)^2 - (52.36)^2 \}$$

$$\text{Or } P = 7.66 \text{ N}$$

Let the spring force corresponding to speed 52.88 r/s be S' .

$$\therefore 2 \times 2 \times (52.88)^2 \times 0.07 = 6g + S'$$

$$\begin{aligned} \therefore (S' - S) &= 2 \times 2 \times 0.07 \times \{ (52.88)^2 - (52.36)^2 \} \\ &= 15.32 \text{ N} \end{aligned}$$

$$\begin{aligned} \text{Sleeve lift for 1\% change} &= \frac{15.32}{s} \\ &= \frac{15.32}{16175.81} = 9.47 \times 10^{-4} \text{ m} \end{aligned}$$

$$\begin{aligned} \therefore \text{Governor power} &= 7.66 \times 9.47 \times 10^{-4} \\ &= 7.25 \times 10^{-3} \text{ Nm} \end{aligned}$$

Example 5.3

The controlling force diagram of a spring controlled governor is a straight line. The weight of each governor ball is 40 N. The extreme radii of rotation of balls are 10 cm and 17.5 cm. The corresponding controlling forces at these radii are 205 N and 400 N. Determine :

- the extreme equilibrium speeds of the governor, and
- the equilibrium speed and the coefficient of insensitiveness at a radius of 15 cm. The friction of the mechanism is equivalent of 2.5 N at each ball.

Solution

Weight of each ball ' w ' = 40 N

$r_1 = 10 \text{ cm}$ and $r_2 = 17.5 \text{ cm}$

$F_{C_1} = 205 \text{ N}$ and $F_{C_2} = 400 \text{ N}$

Let $F_C = ar + b$

when $r_1 = 10 \text{ cm} = 0.1 \text{ m}$ and $F_{C_1} = 205 \text{ N}$

$$205 = b + 0.1a$$

when $r_2 = 17.5 \text{ cm} = 0.175 \text{ m}$ and $F_{C_2} = 400 \text{ N}$

$$400 = b + 0.175a$$

$$\therefore 195 = 0.075a \Rightarrow a = 2600$$

$$\therefore b = 205 - 0.1 \times 2600 = -55$$

$$\therefore F_C = -55 + 2600r$$

$$(a) \text{ For } F_C = 205; \frac{40}{g} \left(\frac{2\pi N_1}{60} \right)^2 \times 0.1 = 205 \text{ N}$$

$$\text{Or } N_1 = 214.1 \text{ rpm}$$

$$\text{For } F_C = 400; r = 0.175 \text{ m}$$

$$\therefore \frac{40}{g} \left(\frac{2\pi N_2}{60} \right)^2 \times 0.175 = 400$$

$$\text{Or } N_2 = 226.1 \text{ rpm}$$

$$(b) F_c = k N^2$$

At radius $r = 15 \text{ cm}$

$$F_c + f_b = k N'^2$$

$$F_c - f_b = k N''^2$$

$$(F_c + f_b) - (F_c - f_b) = k (N'^2 - N''^2)$$

$$\text{Or } 2f_b = k (N' - N'') (N' + N'')$$

$$= 2k (N' - N'') N$$

$$\frac{2f_b}{F_c} = \frac{2k (N' - N'') N}{k N^2} = \frac{2 (N' - N'')}{N}$$

$$\therefore \text{Coefficient of insensitiveness} = \frac{(N' - N'')}{N} = \frac{1}{2} \times \frac{2f_b}{F_c} = \frac{f_b}{F_c}$$

At $r = 0.15 \text{ m}$

$$F_c = -55 + 2600 \times 0.15 = 335 \text{ N}$$

$$\therefore \text{Coefficient of insensitiveness} = \frac{2.5}{335} = 7.46 \times 10^{-3} \text{ Or } 0.746\%$$

5.9 SUMMARY

The governors are control mechanisms and they work on the principle of feedback control. Their basic function is to control the speed within limits when the load on the prime mover changes. They have no control over the change in speed within the cycle. The speed control within the cycle is done by the flywheel.

The governors are classified in three main categories that is centrifugal governors, inertial governor and pickering governor. The use of the two later governors is very limited and in most of the cases centrifugal governors are used. The centrifugal governors are classified into two main categories, gravity controlled type and spring loaded type.

The gravity controlled type of governors are larger in size and require more space as compared to the spring controlled governors. This type of governors are two, i.e. Porter governor and Proell governor. The spring controlled governors are : Hartnell governor, Wilson-Hartnell governor and Hartung governor.

For comparing different type of governors, effort and power is used. They determine whether a particular type of governor is suitable for a given situation or not. To categorise a governor the characteristics can be used. It can be determined whether a governor is stable or isochronous or it is prone to hunting. The friction at the sleeve gives rise to the insensitiveness in the governor. At any particular radius, there shall be two speeds due to the friction. Therefore, it is most desirable that the friction should be as low as possible.

The stability of a spring controlled governor can be determined by drawing controlling force diagram which should have intercept on the negative side of Y-axis.

5.10 KEY WORDS

Watt Governor

: It is a type of governor which does not have load on the sleeve.

Porter Governor

: This is a type of governor which has dead weight at the sleeve and balls are mounted at the hinge.

Hartnell Governor

Governor Effort

Governor Power

Hunting of Governor

Controlling Force

- : It is a spring controlled governor in which balls are mounted on the bell crank lever and sleeve is loaded by spring force.
- : It is the mean force exerted on the sleeve during a given change of speed.
- : It is defined as the work done at the sleeve for a given change in speed.
- : It can occur in governor when the fluctuations in engine speed coincides the natural frequency of oscillations of the governor. In that case governor intensifies the speed variation instead of controlling it.
- : It is the resultant external force which controls the movement of the ball and acts along the radial line towards the axis.

5.11 ANSWERS TO SAQs

Refer the preceding text for all the Answers to SAQs.